

PRODUCT GUIDE

Discrete IGBTs

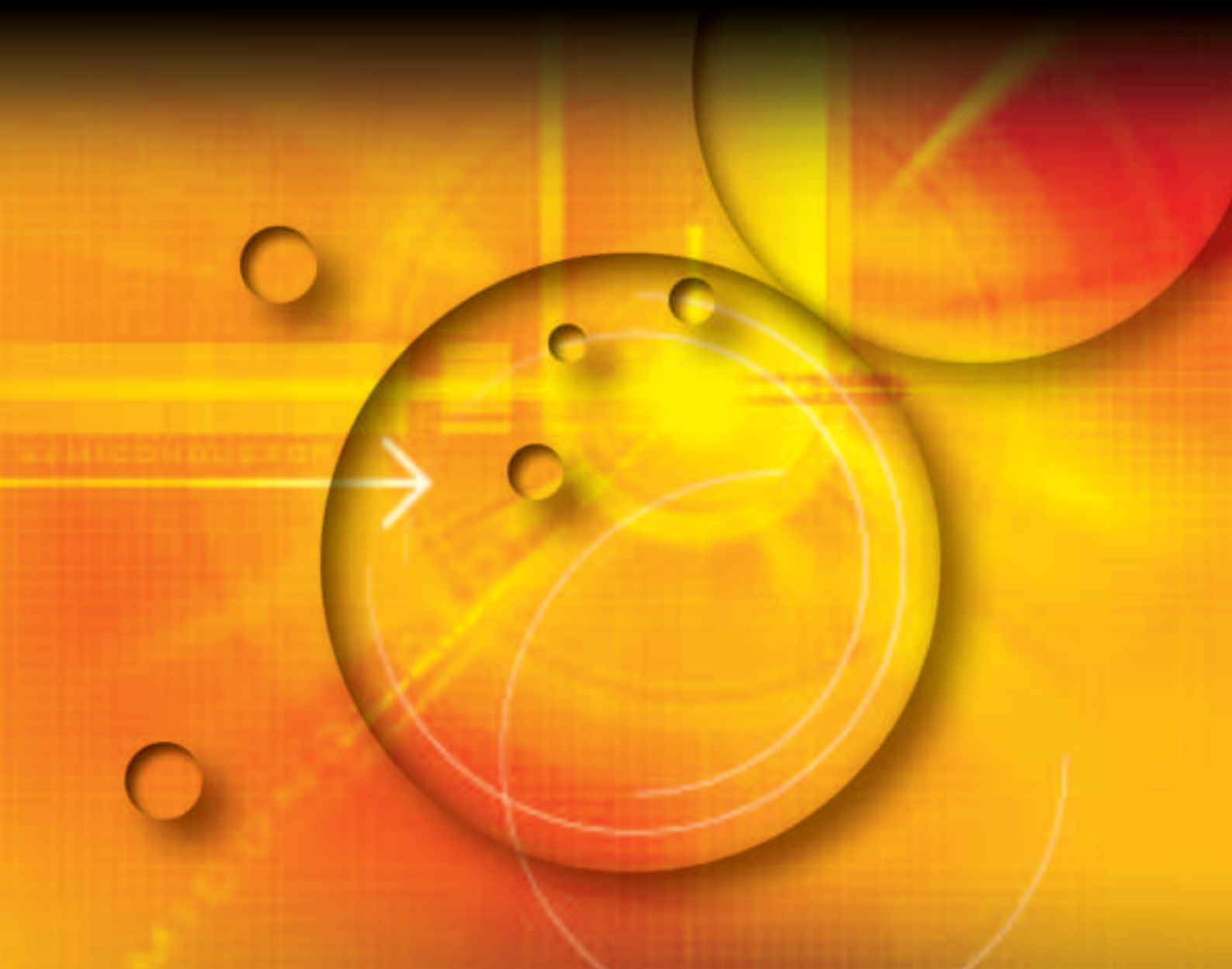

1 Features and Structure

IGBT: Insulated Gate Bipolar Transistor

IGBTs combine the MOSFET advantage of high input impedance with the bipolar transistor advantage of high-voltage drive.

The conductivity modulation characteristics of a bipolar transistor make it ideal for load control applications that require high breakdown voltage and high current.

Toshiba offers a family of fast switching IGBTs, which are low in carrier injection and recombination in carrier.

Features of the Toshiba Discrete IGBTs

The Toshiba discrete IGBTs are available in high-voltage and high-current ratings. They are used in inverter and power conversion circuits for such diverse applications as motor drivers, uninterruptible power supply (UPS) systems, IH cookers, plasma display panels (PDPs), strobe flashes and so on.

- (1) IGBTs also featuring fast switching
- (2) Low collector-emitter saturation voltage even in the large current area
- (3) IGBTs featuring a built-in diode with optimal characteristics tailored to specific applications
- (4) High input impedance allows voltage drives
- (5) Available in a variety of packages

Construction

The basic structure of the planar IGBT consists of four layers (pnpn), as shown in the following figure. Low saturation voltage is achieved by using a pnp transistor to allow conductivity modulation during conduction. Unlike MOSFETs, the IGBT does not have an integral reverse diode, since the collector contact is made on the p⁺ layer.

Planar Structure

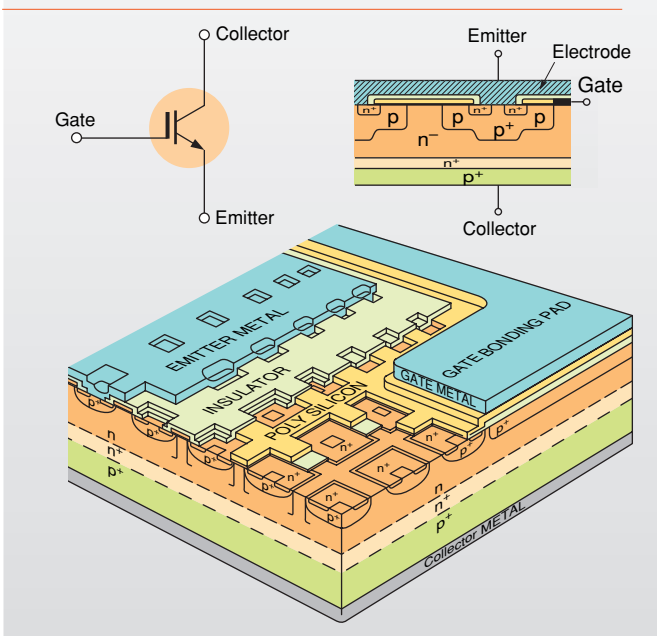

Equivalent Circuit

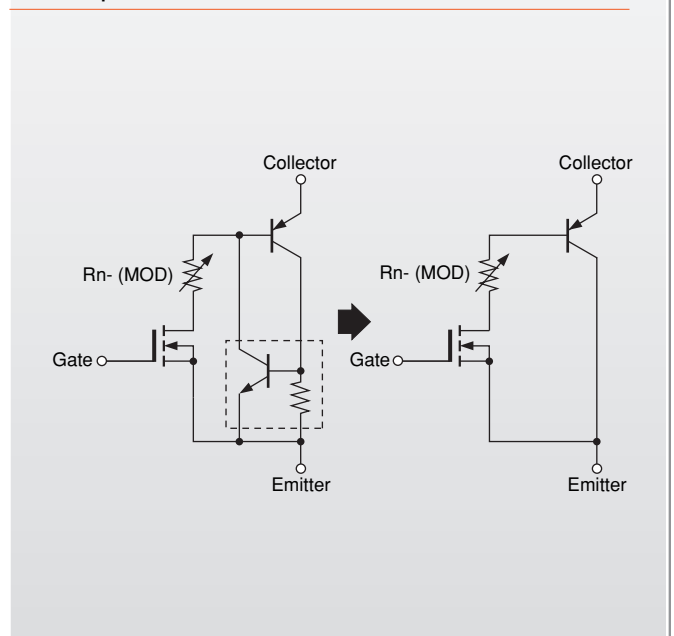

3 Discrete IGBT Product List

Applications and Features	Breakdown Voltage V_{CES} (V) @ $T_a = 25^\circ\text{C}$	IGBT Current Rating I_c (A) @ $T_a = 25^\circ\text{C}$		TSOP-8	TSSOP-8	SOP-8	TO-220NIS	TO-220SIS	TO-220FL	TO-220SM	TO-220AB	TO-3P(N)	TO-3P(N)IS	TO-3P(LH)	
		DC	Pulsed												
General-purpose motors General-purpose inverters Hard switching fc: up to 20 kHz	600	5	10				GT5J301				GT5J311				
		10	20				GT10J303				GT10J312	GT10J301			
		15	30				GT15J301				GT15J311				
		20	40									GT20J301	GT20J101		
		30	60									GT30J301	GT30J101		
		50	100												GT50J301 GT50J102
High ruggedness Series	1200	10	20									GT10Q301	GT10Q101		
		15	30									GT15Q301	GT15Q102		
		25	50											GT25Q301 GT25Q102	
General-purpose inverters Fast switching Hard switching fc: up to 50 kHz	600	10	20				GT10J321								
		15	30				GT15J321								
		20	40				GT20J321								
		30	60									GT30J324	GT30J126		
		50	100									GT30J121		GT50J325 GT50J121	
General-purpose inverters Low- $V_{CE(sat)}$ IGBT	600	15	30						GT15J331						
Resonant switching Soft switching Soft-Switching Series	400	40	100								GT40G121			GT50G321	
		50	100												
		30	100										GT30J322		
	600	37	100										GT35J321		
		40	100									GT40J321	GT40J322		
												GT40J323			
		50	100									GT50J327	GT50J328	GT50J322	
												GT50J328		GT50J322H	
		120										GT50J122			
	900	60	120											GT60J321	
		80	160											GT60J323	
		15	30										GT15M321	GT60J323H	
	1000	50	120											GT80J101B	
		60	120											GT60M303	
		50	120									GT50M322		GT60M323	
1200	60	120											GT60M324		
	50	120									GT50N322A		GT60N303		
	57	120									GT50N324		GT60N322		
1500	60	120											GT60N321		
	42	80									GT40Q321		GT40T302		
PFC	600	30	100										GT30J122		
Strobe flashes	400	130		GT5G133											
		150		GT8G133	GT8G134	GT8G132									
		200		GT8G136	GT10G131										
Plasma display panels	300	120							GF30F122						
		200							GF30F123						
		200							GT45F122						
	400	120							GT45F123						
		200							GT45F124						
		200							GT45F125						
430	200							GT45F127							
	200							GT30G122							
	200							GT45G122							
600	200							GT45G123							
	200							GT45G124							
	200							GT45G125							

GT5G133 : Under development

4 Part Numbering Scheme

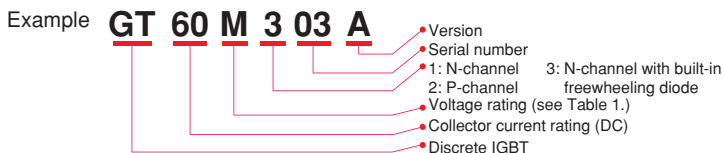

Table 1

Letter	Voltage (V)	Letter	Voltage (V)	Letter	Voltage (V)
C	150	J	600	Q	1200
D	200	K	700	R	1300
E	250	L	800	S	1400
F	300	M	900	T	1500
G	400	N	1000	U	1600
H	500	P	1100	V	1700

5-1 General-Purpose Inverter

The fast-switching (FS) series, a new addition to our third-generation IGBTs, features high ruggedness which helps to improve the energy efficiency of electronic equipment.

General-Purpose Inverters

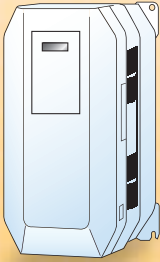

Inverter Air Conditioners

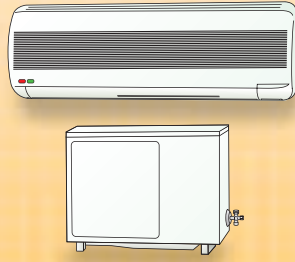

Inverter Washing Machines

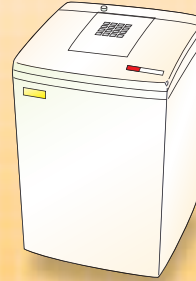

UPS

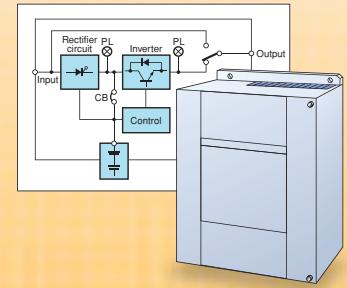

Discrete IGBT Trend

► For general-purpose inverters

Our 3rd generation low-loss and low-noise IGBTs are ideal for inverter applications to reduce switching loss and thus improve energy efficiency. The following graphs compare the thermal and turn-on characteristics of our 3rd generation IGBTs and 500-V MOSFETs

► IC - V_{CE} Temperature Characteristics

Low saturation voltage with minimal temperature dependence

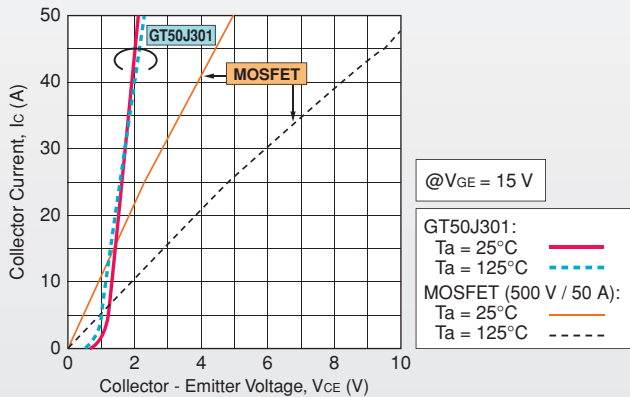

► Turn-On Waveform

Fast reverse-recovery characteristics due to built-in diode with optimal characteristics

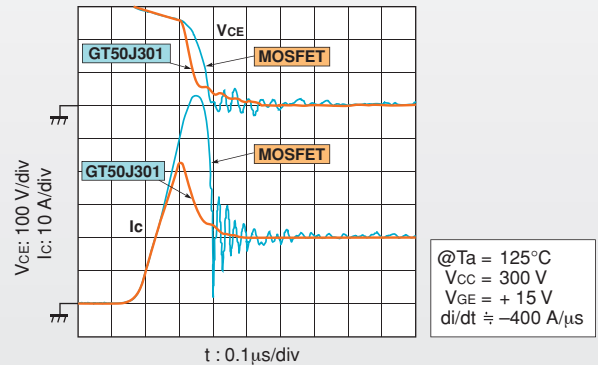

► Power Loss vs. Carrier Frequency Characteristics

Simulation data for inverter applications

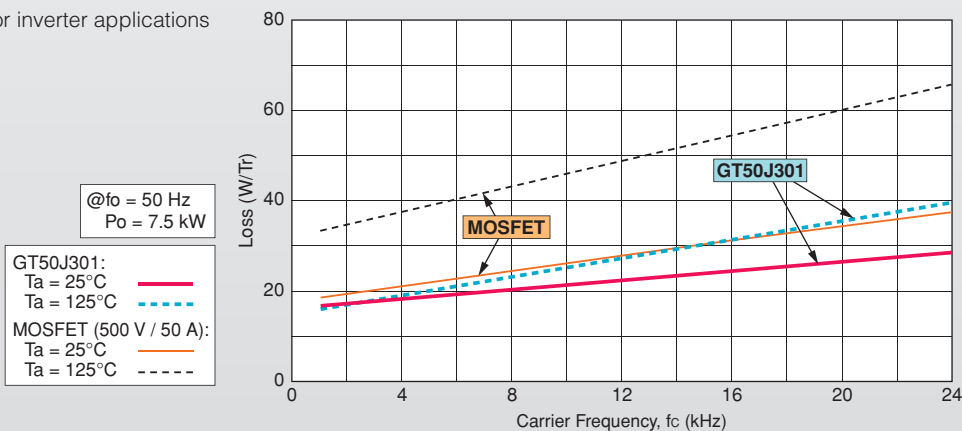

5-1 General-Purpose Inverter

For general-purpose inverters

► Fast-Switching (FS) Series

Compared to the third-generation highly rugged series, the FS series is optimized for switching speed, reducing the total switching loss ($E_{on} + E_{off}$) by 30% (according to Toshiba's comparative test).

► Typical Waveforms

GT20J321(4th generation, FS Series)

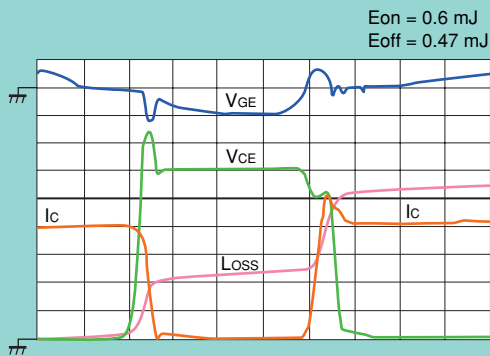

GT20J301(3rd generation)

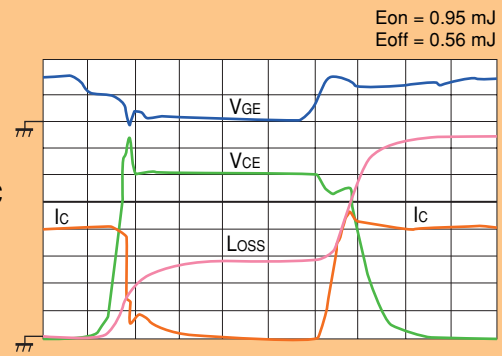

$T_a = 25^\circ\text{C}$

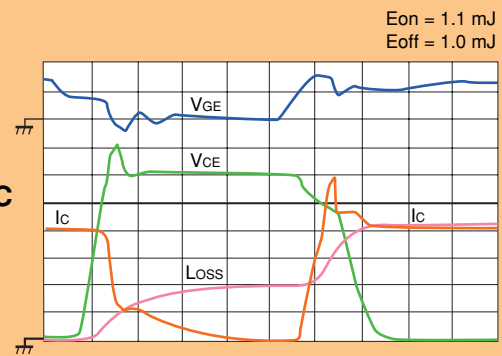
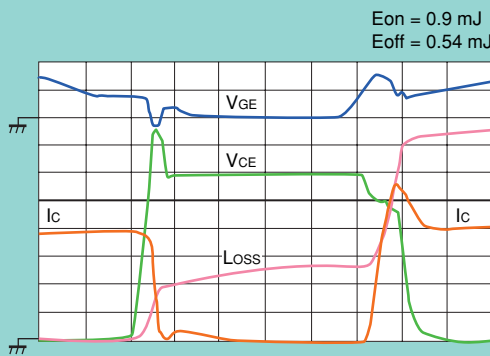

$T_a = 125^\circ\text{C}$

(Loss: 0.5 mJ/div)

(V_{CE} : 50 V/div, I_c : 5 A/div, V_{GE} : 10 V/div, Loss: 0.2 mJ/div, t : 0.2 μs /div)

Reduced switching loss of fast-switching IGBTs in comparison with high ruggedness IGBTs

Test condition: $I_C = 20\text{ A}$, $V_{GE} = 15\text{ V}$, $R_G = 33\ \Omega$, $T_a = 125^\circ\text{C}$, with inductive load, $V_{CC} = 300\text{ V}$

► Turn-On Loss

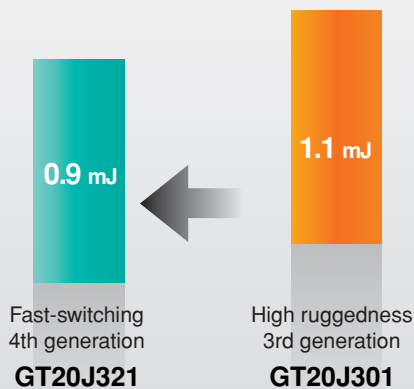

► Turn-Off Loss

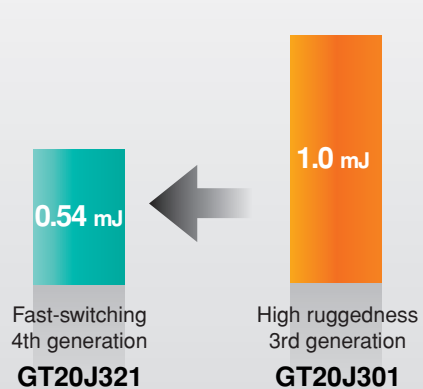

► Circuit Configurations

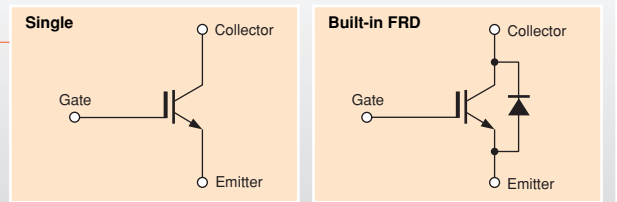

► 600-V and 1200-V IGBTs (3rd Generation)

Main Applications	Features	Part Number	Absolute Maximum Ratings				Package	Circuit Configuration (*1)	VCE(sat) Typ.			tr Typ.		Remarks	
			VCEs (V)	Ic		Pc (W)			@VCE (V)	@Ic (A)	@VGE (V)	(μs)	Load (*2)		
				DC (A)	Pulsed (A)										Tc = 25°C
Motor driving (UPS/PFC)	High VCEs (1200V)	GT10Q101	1200	10	20	140	TO-3P(N)	◆	2.1	10	15	0.16	L		
		GT10Q301	1200	10	20	140	TO-3P(N)	–	Built-in FRD	2.1	10	15	0.16	L	
		GT15Q102	1200	15	30	170	TO-3P(N)	–	◆	2.1	15	15	0.16	L	
		GT15Q301	1200	15	30	170	TO-3P(N)	–	Built-in FRD	2.1	15	15	0.16	L	
		GT25Q102	1200	25	50	200	TO-3P(LH)	–	◆	2.1	25	15	0.16	L	
		GT25Q301	1200	25	50	200	TO-3P(LH)	–	Built-in FRD	2.1	25	15	0.16	L	
	High VCEs (600V)	GT5J301	600	5	10	28	TO-220NIS	–	Built-in FRD	2.1	5	15	0.15	L	
		GT5J311	600	5	10	45	TO-220SM	SMD	Built-in FRD	2.1	5	15	0.15	L	
		GT10J301	600	10	20	90	TO-3P(N)	–	Built-in FRD	2.1	10	15	0.15	L	
		GT10J303	600	10	20	30	TO-220NIS	–	Built-in FRD	2.1	10	15	0.15	L	
		GT10J312	600	10	20	60	TO-220SM	SMD	Built-in FRD	2.1	10	15	0.15	L	
		GT15J301	600	15	30	35	TO-220NIS	–	Built-in FRD	2.1	15	15	0.15	L	
		GT15J311	600	15	30	70	TO-220FL	–	Built-in FRD	2.1	15	15	0.15	L	
		GT15J311	600	15	30	70	TO-220SM	SMD	Built-in FRD	2.1	15	15	0.15	L	
		GT20J101	600	20	40	130	TO-3P(N)	–	◆	2.1	20	15	0.15	L	
		GT20J301	600	20	40	130	TO-3P(N)	–	Built-in FRD	2.1	20	15	0.15	L	
		GT30J101	600	30	60	155	TO-3P(N)	–	◆	2.1	30	15	0.15	L	
		GT30J301	600	30	60	155	TO-3P(N)	–	Built-in FRD	2.1	30	15	0.15	L	
GT50J102	600	50	100	200	TO-3P(LH)	–	◆	2.1	50	15	0.15	L			
GT50J301	600	50	100	200	TO-3P(LH)	–	Built-in FRD	2.1	50	15	0.15	L			
Power factor correction	Low-frequency switching	GT30J122	600	30	100	75	TO-3P(N)IS	–	◆	2.1	50	15	0.25	R	Partial Switching Converter

► 600-V Fast-Switching IGBTs (4th Generation)

(FS: Fast Switching)

Main Applications	Features	Part Number	Absolute Maximum Ratings				Package	Circuit Configuration (*1)	VCE(sat) Typ.			tr Typ.		Remarks	
			VCEs (V)	Ic		Pc (W)			@VCE (V)	@Ic (A)	@VGE (V)	(μs)	Load (*2)		
				DC (A)	Pulsed (A)										Tc = 25°C
Inverter power supplies (UPS/PFC/motor)	Fast switching	GT10J321	600	10	20	29	TO-220NIS	–	Built-in FRD	2.0	10	15	0.05	L	
		GT15J321	600	15	30	30	TO-220NIS	–	Built-in FRD	1.9	15	15	0.03	L	
		GT15J331	600	15	30	70	TO-220SM	SMD	Built-in FRD	1.75	15	15	0.10	L	Low VCE(sat)
		GT20J321	600	20	40	45	TO-220NIS	–	Built-in FRD	2.0	20	15	0.04	L	
		GT30J121	600	30	60	170	TO-3P(N)	–	◆	2.0	30	15	0.05	L	
		GT30J126	600	30	60	90	TO-3P(N)IS	–	◆	1.95	30	15	0.05	L	Isolation Package
		GT30J324	600	30	60	170	TO-3P(N)	–	Built-in FRD	2.0	30	15	0.05	L	
		GT50J121	600	50	100	240	TO-3P(LH)	–	◆	2.0	50	15	0.05	L	
		GT50J325	600	50	100	240	TO-3P(LH)	–	Built-in FRD	2.0	50	15	0.05	L	

*1 ◆ : Single
FRD: Fast Recovery Diode
*2 R : Resistive load
L : Inductive load

5-2 Soft-Switching Applications

Static inverters in IH cooktops, IH rice cookers and microwave ovens utilize a soft-switching technique which exhibits low switching loss. Toshiba offers IGBTs suitable for soft-switching applications.

Microwave Ovens



IH Rice Cookers



IH Cookers

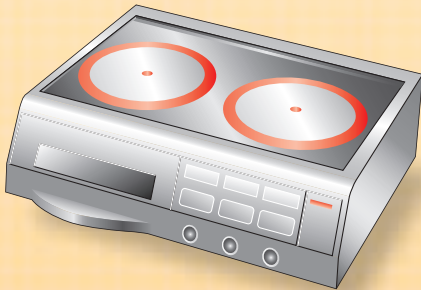

MFPs

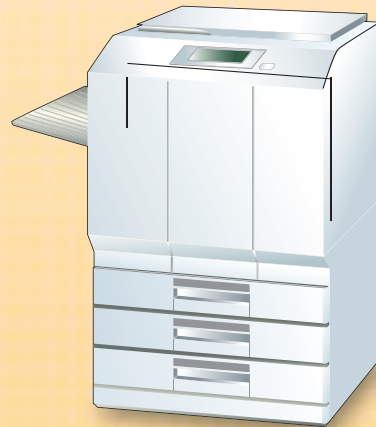

AC Input Voltage	Circuit	IGBT Rating	
100 V to 120 V	<p>Voltage Resonance</p>	<p>Waveform</p>	<p>$V_{CES} = 900 \text{ V to } 1000 \text{ V}$ $I_c = 15 \text{ A to } 60 \text{ A}$</p>
200 V to 240 V			<p>$V_{CES} = 1200 \text{ V to } 1500 \text{ V}$ $I_c = 40 \text{ A}$</p>
100 V to 240 V	<p>Current Resonance</p>	<p>Waveform</p>	<p>$V_{CES} = 400 \text{ V}$ $I_c = 40 \text{ A to } 50 \text{ A}$</p>
			<p>$V_{CES} = 600 \text{ V}$ $I_c = 30 \text{ A to } 80 \text{ A}$</p>

IH: Induction heating
MFP: Multifunction Printer

► Circuit Configurations

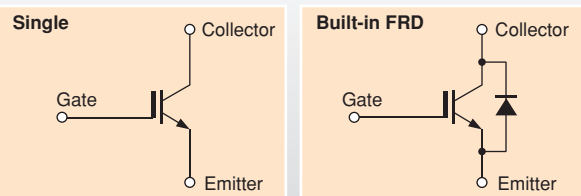

► IGBTs for Soft-Switching Applications

Main Applications	Features	Part Number	Absolute Maximum Ratings			Package	Circuit Configuration (*1)	V _{CE(sat)} Typ.			t _r Typ.		Remarks	
			V _{CEs} (V)	I _c				P _c T _c = 25°C (W)	@I _c (A)	@V _{GE} (V)	tr (μs)	Load (*2)		
				DC (A)	Pulsed (A)									
IH rice cookers and IH cooktops	AC 100 V	GT40G121	400	40	80	100	TO-220AB	◆	1.8	40	15	0.30		
		GT50G321		50	100	130	TO-3P(LH)		1.8	50	15	0.30		
	AC 200 V	Current resonance	GT30J322	600	30	60	75	TO-3P(N)IS		2.1	50	15	0.25	
			GT35J321		37	100	75			1.9	50	15	0.19	
			GT40J321		40	100	110	TO-3P(N)		2.1	40	15	0.15	Fast switching
			GT40J322		40	100	110			2.0	40	15	0.24	
			GT40J323		40	80	120		2.0	40	15	0.06	5th generation	
			GT50J322		50	100	130	TO-3P(LH)	Built-in FRD	2.1	50	15	0.25	
			GT50J322H		50	100	130			2.2	50	15	0.16	Fast switching
			GT50J327		50	100	140	TO-3P(N)		1.9	50	15	0.19	
			GT50J328		50	120	140			2.0	50	15	0.10	Fast switching
			GT60J321		60	120	200			1.55	60	15	0.30	
			GT60J323		60	120	170	TO-3P(LH)		1.9	60	15	0.16	
			GT60J323H		60	120	170			2.1	60	15	0.12	R Fast switching
AC 100 V	Voltage resonance	GT15M321	900	15	30	55	TO-3P(N)IS		1.8	15	15	0.20		
		GT50M322		50	120	156	TO-3P(N)		2.1	60	15	0.25		
		GT60M303		60	120	170	TO-3P(LH)		2.1	60	15	0.25		
		GT60M323		60	120	200			2.3	60	15	0.09	Fast switching	
		GT60M324		60	120	150		1.65	60	15	0.11	6th generation		
		GT50N321		50	120	156	TO-3P(N)	Built-in FWD	2.5	60	15	0.25		
		GT50N322A		50	120	156				2.2	60	15	0.10	Fast switching
		GT50N324		50	120	150			1.9	60	15	0.12	6th generation	
		GT60N321		60	120	170	TO-3P(LH)		2.3	60	15	0.25		
		GT60N322		57	120	200			2.4	40	15	0.11	Fast switching	
AC 200 V		GT40Q321	1200	40	80	170	TO-3P(N)		2.8	60	15	0.41		
		GT40T302	1500	40	80	200	TO-3P(LH)		3.7	40	15	0.23	High V _{CEs}	

*1 ◆ : Single
 FRD: Fast Recovery Diode
 FWD: Free Wheeling Diode
 *2 R : Resistive load
 L : Inductive load
 : Under development

5-2 Soft-Switching Applications

► Comparisons Between Hard and Soft Switching (diagrams shown only as a guide)

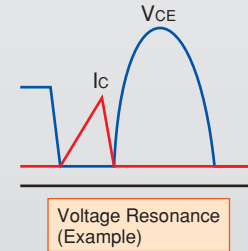
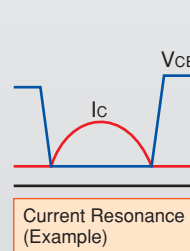
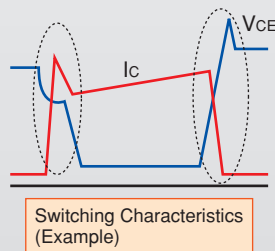
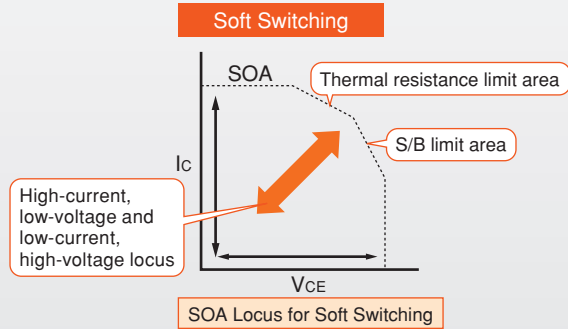
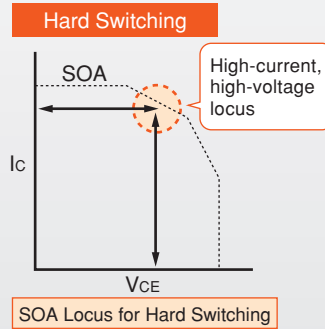

5-3 Strobe Flash Applications

Strobe flash control is now prevalent in digital still cameras. Package sizes are getting smaller, and logic levels are increasingly used to represent the gate drive voltage. Toshiba offers compact IGBTs featuring low gate drive voltage.

- As a voltage-controlled device, the IGBT requires only a few components for drive circuit.
- IGBTs require fewer components for the strobe flash circuit (compared to SCRs).
- Strobe flash IGBTs are capable of switching large currents.

DSC, Compact Camera

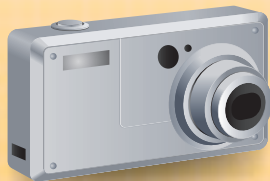

Single-Lens Reflex Camera

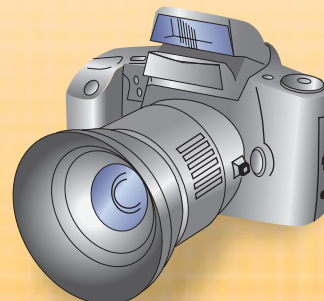

5-3 Strobe Flash Applications

Product List

► For strobe flashes

2.5-V to 4.0-V Gate Drive Series

The IGBT can operate with a gate drive voltage of 2.5 V to 4.0 V. The common 3.3-V or 5-V internal power supply in a camera can be used as a gate drive power supply to simplify the power supply circuitry. A zener diode is included between the gate and emitter to provide ESD surge protection.

► Example of an IGBT Gate Drive Circuit (3.3-V Power Supply)

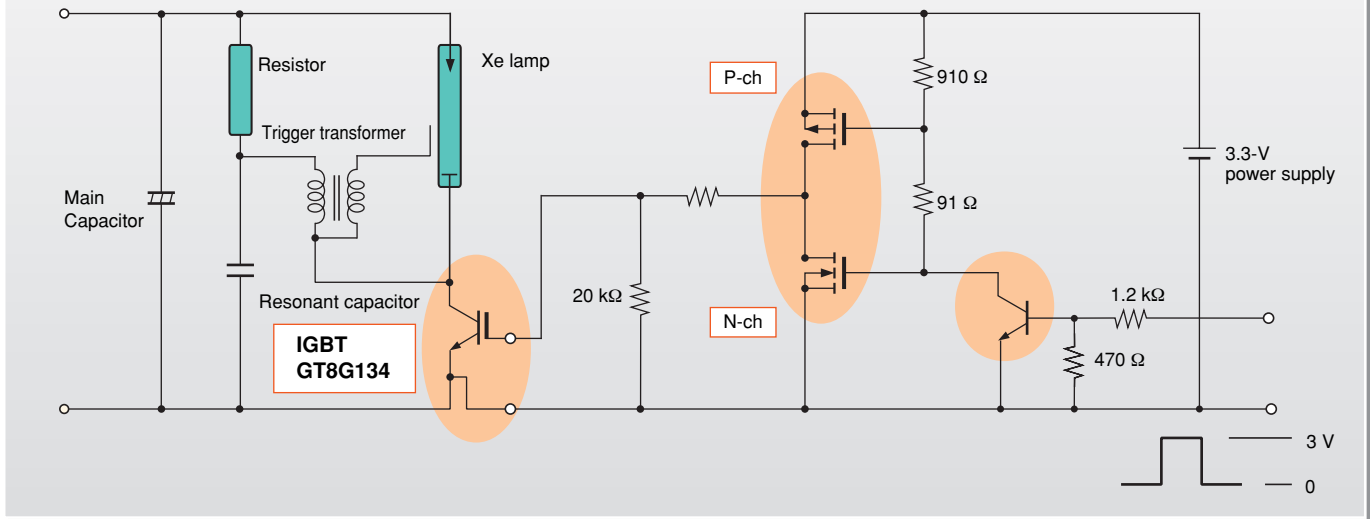

3.3-V Power Supply

Part Number	V _{CES} / I _c	V _{CE(sat)} (V)		P _c (W) @T _a = 25°C	Package	Remarks
		(V)	V _{GE} / I _c			
GT5G133	400 V / 130 A	3.4	2.5 V / 130 A	0.9	TSON-8*1	7th generation
GT8G136	400 V / 150 A	3.5	3 V / 150 A	1.1	TSSOP-8*2	5th generation
GT8G134	400 V / 150 A	3.4	2.5 V / 150 A	1.1	TSSOP-8*2	6th generation

*1: Under development

5-V Power Supply

Part Number	V _{CES} / I _c	V _{CE(sat)} (V)		P _c (W) @T _a = 25°C	Package	Remarks
		(V)	V _{GE} / I _c			
GT8G132	400 V / 150 A	2.3	4.0 V / 150 A	1.1	SOP-8*1	5th generation
GT8G133	400 V / 150 A	2.9	4.0 V / 150 A	1.1	TSSOP-8*1	5th generation
GT10G131	400 V / 200 A	2.3	4.0 V / 200 A	1.9	SOP-8*1	5th generation

*1: Board connection example

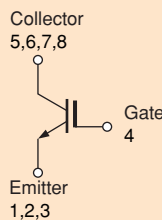

*2: Board connection example

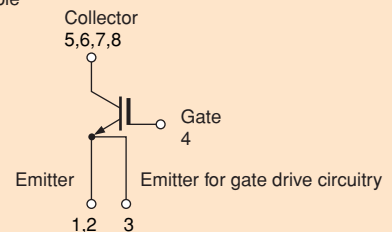

All the emitter terminals should be connected together.

5-4 Plasma Display Panel Applications

Plasma Displays

Parallel MOSFETs have been used for the drive circuitry of plasma display panels (PDPs). Recently, however, IGBTs are commonly used in large current applications due to their superior current conduction capability.



▶ Example of a Plasma Display Panel Drive Circuit

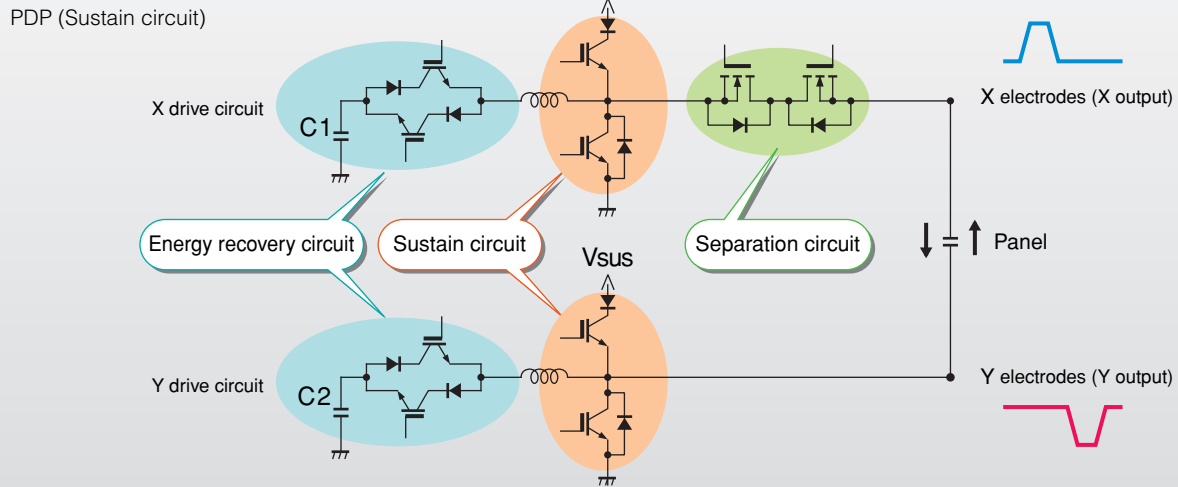

Product List

▶ For plasma display panels

300-V IGBTs

Part Number	$V_{CES} / I_{cp} @ 3 \mu s$	$V_{CE(sat)} (V) \text{ Max}$	$P_c (W) @ T_c = 25^\circ C$	Package	Remarks
GT30F122	300 V / 120 A*	2.9 (@120 A)	25	TO-220SIS	5th generation
GT30F123	300 V / 200 A	2.1 (@120 A)	25	TO-220SIS	6th generation
GT45F122	300 V / 200 A	2.7 (@120 A)	25	TO-220SIS	5th generation
GT45F123	300 V / 200 A	2.4 (@120 A)	26	TO-220SIS	5th generation
GT45F124	300 V / 200 A	2.1 (@120 A)	29	TO-220SIS	5th generation
GT45F125	300 V / 200 A	1.45 (@120 A)	29	TO-220SIS	5th generation
GT45F127	300 V / 200 A	1.6 (@120 A)	26	TO-220SIS	6th generation
GT45F131	300 V / 200 A	2.1 (@120 A)	160	TO-220SM	5th generation

*: @100 μs

400-V IGBTs

Part Number	$V_{CES} / I_{cp} @ 3 \mu s$	$V_{CE(sat)} (V) \text{ Max}$	$P_c (W) @ T_c = 25^\circ C$	Package	Remarks
GT30G122	400 V / 120 A*	2.6 (@120 A)	25	TO-220SIS	5th generation
GT30G123	430 V / 200 A	2.2 (@120 A)	25	TO-220SIS	6th generation
GT45G122	400 V / 200 A	2.9 (@120 A)	25	TO-220SIS	5th generation
GT45G123	400 V / 200 A	2.6 (@120 A)	26	TO-220SIS	5th generation
GT45G124	400 V / 200 A	2.3 (@120 A)	29	TO-220SIS	5th generation
GT45G125	400 V / 200 A	1.6 (@120 A)	29	TO-220SIS	5th generation
GT45G127	430 V / 200 A	1.7 (@120 A)	26	TO-220SIS	6th generation
GT45G131	400 V / 200 A	2.3 (@120 A)	160	TO-220SM	5th generation

*: @100 μs

600-V IGBTs

Part Number	$V_{CES} / I_{cp} @ 3 \mu s$	$V_{CE(sat)} (V) \text{ Max}$	$P_c (W) @ T_a = 25^\circ C$	Package	Remarks
GT30J124	600 V / 200 A	2.4 (@120 A)	26	TO-220SIS	5th generation

6 Package Dimensions

Unit: mm

TSSOP-8

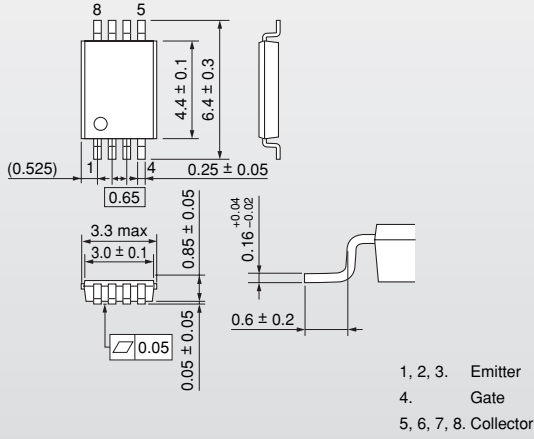

SOP-8

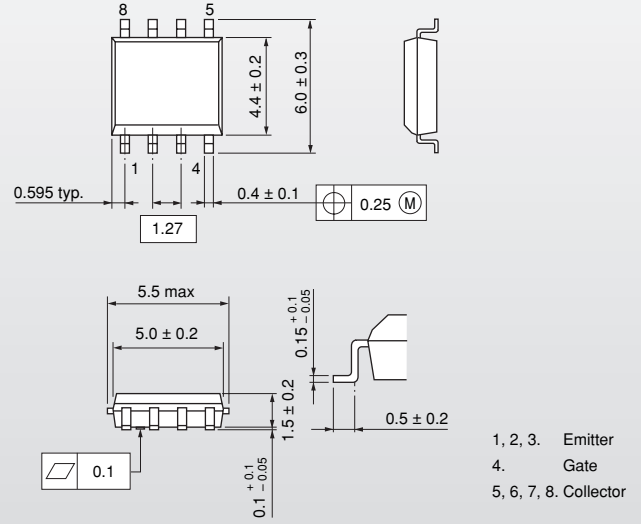

TSOP-8

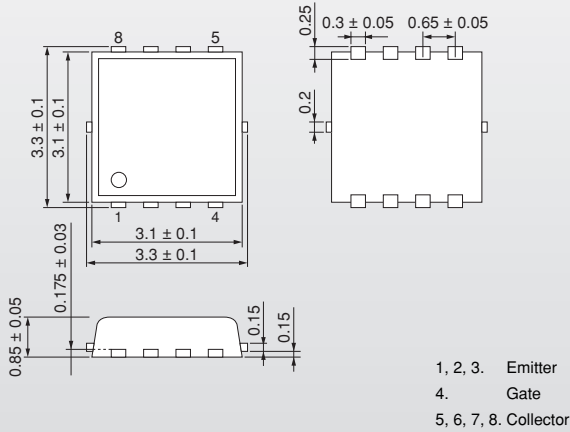

TO-220NIS

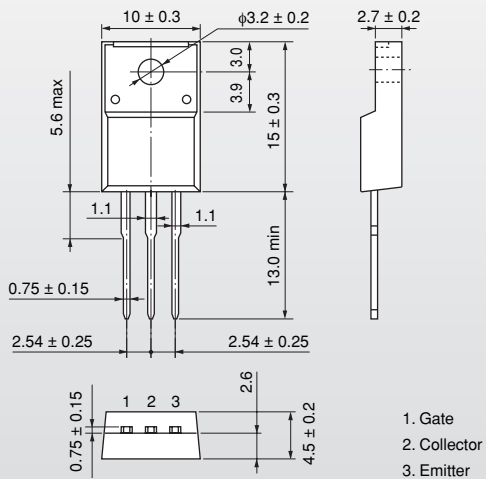

TO-220SIS

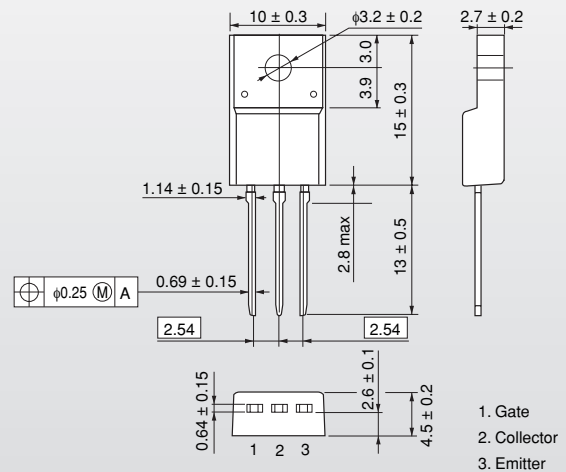

6 Package Dimensions

Unit: mm

▶ TO-220AB

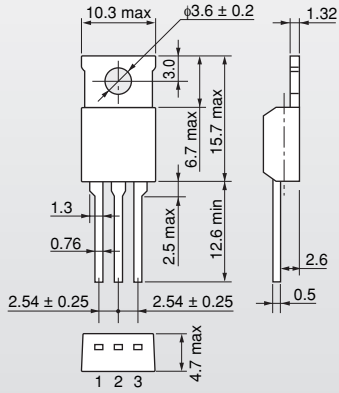

1. Gate
2. Collector
3. Emitter

▶ TO-220SM

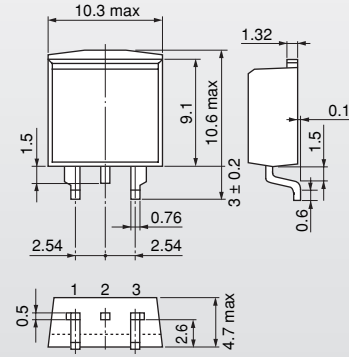

1. Gate
2. Collector
3. Emitter

▶ TO-3P(N)

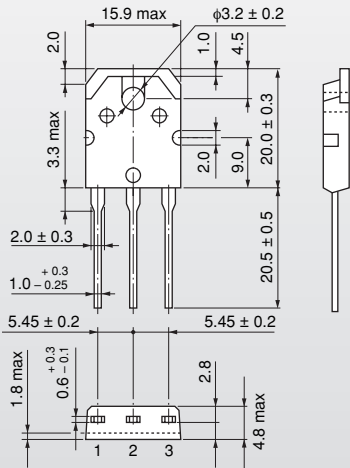

1. Gate
2. Collector
3. Emitter

▶ TO-3P(LH)

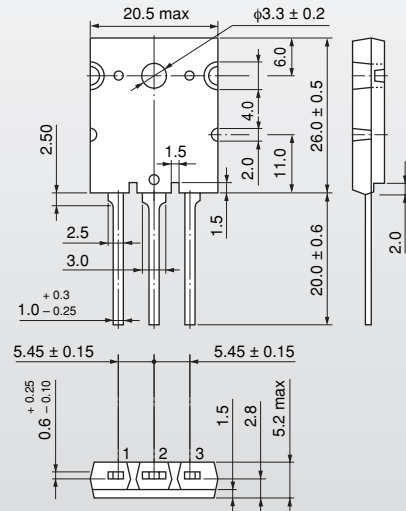

1. Gate
2. Collector
3. Emitter

▶ TO-3P(N)IS

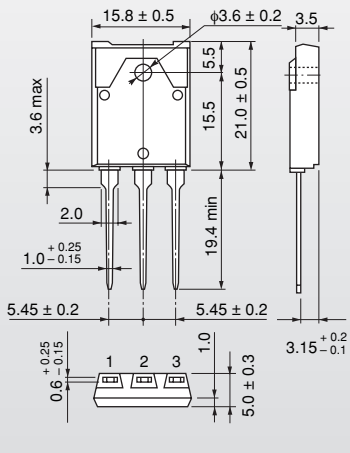

1. Gate
2. Collector
3. Emitter

7 Final-Phase and Obsolete Products

The following products are in stock but are being phased out of production. The recommended replacements that continue to be available are listed in the right-hand column. However, the characteristics of the recommended replacements may not be exactly the same as those of the final-phase and obsolete products. Before using a recommended replacement, be sure to check that it is suitable for use under the intended operating conditions.

Audio amps	Final-Phase or Obsolete Product	Absolute Maximum Ratings		Package	Recommended Obsolete Replacements	Absolute Maximum Ratings		Package
		V _{CES} (V)	I _c (A) DC			V _{CES} (V)	I _c (A) DC	
Soft switching Resonant switching	MG30T1AL1	1500	30	IH	–	–	–	–
	MG60M1AL1	900	60	IH	GT60M303	900	60	TO-3P(LH)
	GT40M101	900	40	TO-3P(N)IS	–	–	–	–
	GT40M301	900	40	TO-3P(LH)	GT60M303	900	60	TO-3P(LH)
	GT40Q322	1200	39	TO-3P(N)	GT40Q321	1200	42	TO-3P(N)
	GT40Q323	1200	39	TO-3P(N)	GT40Q321	1200	42	TO-3P(N)
	GT40T101	1500	40	TO-3P(LH)	–	–	–	–
	GT40T301	1500	40	TO-3P(LH)	GT40T302	1500	40	TO-3P(LH)
	GT50L101	800	50	TO-3P(L)	GT60M303	900	60	TO-3P(LH)
	GT50M101	900	50	TO-3P(L)	GT60M303	900	60	TO-3P(LH)
	GT50Q101	1200	50	IH	–	–	–	–
	GT50S101	1400	50	IH	–	–	–	–
	GT50T101	1500	50	IH	–	–	–	–
	GT60J101	600	60	TO-3P(L)	GT80J101B	600	60	TO-3P(LH)
	GT60J322	600	60	TO-3P(LH)	GT60J321	600	60	TO-3P(LH)
	GT60M101	900	60	TO-3P(L)	GT60M303	900	60	TO-3P(LH)
	GT60M102	900	60	TO-3P(L)	GT60M303	900	60	TO-3P(LH)
	GT60M103	900	60	TO-3P(L)	GT60M303	900	60	TO-3P(LH)
	GT60M104	900	60	TO-3P(L)	GT60M303	900	60	TO-3P(LH)
	GT60M105	900	60	TO-3P(L)	GT60M303	900	60	TO-3P(LH)
	GT60M301	900	60	TO-3P(LH)	GT60M303	900	60	TO-3P(LH)
	GT60M302	900	60	TO-3P(LH)	GT60M303	900	60	TO-3P(LH)
	GT60M305	900	60	TO-3P(LH)	GT60M303	900	60	TO-3P(LH)
	GT60M322	950	60	TO-3P(LH)	GT60N321	1000	60	TO-3P(LH)
	GT60N323	1050	60	TO-3P(LH)	GT60N322	1000	57	TO-3P(LH)
GT80J101	600	80	TO-3P(L)	GT80J101B	600	80	TO-3P(LH)	
GT80J101A	600	80	TO-3P(LH)	GT80J101B	600	80	TO-3P(LH)	
General-purpose motors General-purpose inverters	GT8J101	600	8	TO-220NIS	GT10J303	600	10	TO-220NIS
	GT8J102	600	8	TO-220SM	GT10J312	600	10	TO-220SM
	GT8N101	1000	8	TO-3P(N)	GT10Q101	1200	10	TO-3P(N)
	GT8Q101	1200	8	TO-3P(N)	GT10Q101	1200	10	TO-3P(N)
	GT8Q102	1200	8	TO-220SM	–	–	–	–
	GT10Q311	1200	10	TO-3P(SM)	–	–	–	–
	GT15J101	600	15	TO-3P(N)	GT20J101	600	20	TO-3P(N)
	GT15J102	600	15	TO-220NIS	GT15J301	600	15	TO-220NIS
	GT15J103	600	15	TO-220SM	GT15J311	600	15	TO-220SM
	GT15N101	1000	15	TO-3P(N)	GT15Q102	1200	15	TO-3P(N)
	GT15Q101	1200	15	TO-3P(N)	GT15Q102	1200	15	TO-3P(N)
	GT15Q311	1200	15	TO-3P(SM)	–	–	–	–
	GT20J311	600	20	TO-3P(SM)	–	–	–	–
	GT25H101	500	25	TO-3P(N)	GT30J121	600	30	TO-3P(N)
	GT25J101	600	25	TO-3P(N)	GT30J121	600	30	TO-3P(N)
	GT25J102	600	25	TO-3P(N)IS	GT30J126	600	30	TO-3P(N)
	GT25Q101	1200	25	TO-3P(LH)	GT25Q102	1200	25	TO-3P(LH)
	GT30J311	600	30	TO-3P(SM)	–	–	–	–
	GT50J101	600	50	TO-3P(L)	GT50J121	600	50	TO-3P(LH)
	Strobe flashes	GT5G101	400	130 (pulsed)	NPM	–	–	–
GT5G102		400	130 (pulsed)	DP	–	–	–	–
GT5G103		400	130 (pulsed)	DP	–	–	–	–
GT8G101		400	130 (pulsed)	NPM	–	–	–	–
GT8G102		400	150 (pulsed)	NPM	–	–	–	–
GT8G103		400	150 (pulsed)	DP	–	–	–	–
GT10G101		400	130 (pulsed)	TO-220NIS	–	–	–	–
GT10G102		400	130 (pulsed)	TO-220NIS	–	–	–	–
GT15G101		400	170 (pulsed)	TO-220NIS	–	–	–	–
GT20G101		400	130 (pulsed)	TO-220FL	–	–	–	–
GT20G102		400	130 (pulsed)	TO-220FL	–	–	–	–
GT25G101		400	170 (pulsed)	TO-220FL	–	–	–	–
GT25G102		400	150 (pulsed)	TO-220FL	–	–	–	–
GT50G101		400	100 (pulsed)	TO-3P(N)	–	–	–	–
GT50G102		400	100 (pulsed)	TO-3P(N)	–	–	–	–
GT75G101	400	150 (pulsed)	TO-3P(N)	–	–	–	–	
Audio amps	GT20D101	250	20	TO-3P(L)	–	–	–	–
	GT20D201	–250	–20	TO-3P(L)	–	–	–	–

Toshiba America Electronic Components, Inc.

Headquarters-Irvine, CA
19900 MacArthur Boulevard,
Suite 400, Irvine, CA 92612, U.S.A.
Tel: (949)623-2900 Fax: (949)474-1330

Buffalo Grove (Chicago)
2150 E. Lake Cook Road, Suite 310,
Buffalo Grove, IL 60089, U.S.A.
Tel: (847)484-2400 Fax: (847)541-7287

Duluth, GA (Atlanta)
3700 Crestwood Pkwy, #160,
Duluth, GA 30096, U.S.A.
Tel: (770)931-3363 Fax: (770)931-7602

San Jose Engineering Center, CA
2590 Orchard Parkway San Jose,
CA 95131, U.S.A.
Tel: (408)526-2400 Fax: (408)526-2410

Wixom (Detroit)
48679 Alpha Drive, Suite 120, Wixom,
MI 48393 U.S.A.
Tel: (248)347-2607 Fax: (248)347-2602

Toshiba Electronics do Brasil Ltda.
Rua Machado Bittencourt, 361, CJ, 1102,
Bairro Vila Clementino, San Paulo, SP,
CEP 04044-001, Brasil
Tel: (011)5085-5990 Fax: (011)5085-5995

Toshiba India Private Ltd.
6F DR. Gopal Das Bhawan 28,
Barakhamba Road, New Delhi, 110001, India
Tel: (011)2331-8422 Fax: (011)2371-4603

Toshiba Electronics Europe GmbH

Düsseldorf Head Office
Hansaallee 181, D-40549 Düsseldorf,
Germany
Tel: (0211)5296-0 Fax: (0211)5296-400

France Branch
Les Jardins du Golf 6 rue de Rome F-93561,
Rosny-Sous-Bois, Cedex, France
Tel: (1)48-12-48-12 Fax: (1)48-94-51-15

Italy Branch
Centro Direzionale Colleoni,
Palazzo Perseo 3,
I-20041 Agrate Brianza, (Milan), Italy
Tel: (039)68701 Fax: (039)6870205

Spain Branch
Parque Empresarial, San Fernando, Edificio Europa,
1ª Planta, E-28831 Madrid, Spain
Tel: (91)660-6798 Fax: (91)660-6799

U.K. Branch
Delta House, The Crescent Southwood Business Park
Farnborough, Hampshire GU14 0NL, U.K.
Tel: (0870)060-2370 Fax: (01252)53-0250

Sweden Branch
Gustavslundsvägen 18, 5th Floor,
S-167 15 Bromma, Sweden
Tel: (08)704-0900 Fax: (08)80-8459

Toshiba Electronics Asia (Singapore) Pte. Ltd.
438B Alexandra Road, #06-08/12 Alexandra
Technopark, Singapore 119968
Tel: (6278)5252 Fax: (6271)5155

Toshiba Electronics Service (Thailand) Co., Ltd.
135 Moo 5, Bangkadi Industrial Park, Tivanon Road,
Pathumthani, 12000, Thailand
Tel: (02)501-1635 Fax: (02)501-1638

Toshiba Electronics Trading (Malaysia) Sdn. Bhd.

Kuala Lumpur Head Office
Suite W1203, Wisma Conspiant, No.2,
Jalan SS 16/4, Subang Jaya, 47500 Petaling Jaya,
Selangor Darul Ehsan, Malaysia
Tel: (03)5631-6311 Fax: (03)5631-6307

Penang Office
Suite 13-1, 13th Floor, Menara Penang Garden,
42-A, Jalan Sultan Ahmad Shah,
10050 Penang, Malaysia
Tel: (04)226-8523 Fax: (04)226-8515

Toshiba Electronics Philippines, Inc.
26th Floor, Citibank Tower, Valero Street, Makati,
Manila, Philippines
Tel: (02)750-5510 Fax: (02)750-5511

Toshiba Electronics Asia, Ltd.

Hong Kong Head Office
Level 11, Tower 2, Grand Century Place, No.193,
Prince Edward Road West, Mongkok, Kowloon, Hong Kong
Tel: 2375-6111 Fax: 2375-0969

Beijing Office
Room 814, Beijing Fortune Building, No.5 Dong San Huan Bei-Lu,
Chao Yang District, Beijing, 100004, China
Tel: (010)6590-8796 Fax: (010)6590-8791

Chengdu Office
Room 2508A, 2 Zongfu Street, Times Plaza,
Chengdu 610016 Sichuan, China
Tel: (028)8675-1773 Fax: (028)8675-1065

Qingdao Office
Room 4(D-E), 24F, International Financial Center,
59 Xiang Gang Zhong Road, Qingdao 266071, Shandong, China
Tel: (532)8579-3328 Fax: (532)8579-3329

Toshiba Electronics Shenzhen Co., Ltd.
28/F, Excellence Times Square Building, 4068 Yi Tian Road,
Fu Tian District, Shenzhen 518048, China
Tel: (0755)2399-6897 Fax: (0755)2399-5573

Toshiba Electronics (Shanghai) Co., Ltd.

Shanghai Head Office
11F, HSBC Tower, 1000 Lujiazui Ring Road,
Pudong New Area, Shanghai 200120, China
Tel: (021)6841-0666 Fax: (021)6841-5002

Hangzhou Office
502 JiaHua International Business Center,
No.28 HangDa Road, Hangzhou, 310007, China
Tel: (0571)8717-5004 Fax: (0571)8717-5013

Nanjing Office
23F Shiji Shangmao Plaza,
No.49 Zhong Shan South Road, Nanjing, 210005, China
Tel: (025)8689-0070 Fax: (025)8689-0125

Toshiba Electronics (Dalian) Co., Ltd.
14/F, Senmao Building, 147, Zhongshan Road,
Xigang Dist., Dalian, 116011, China
Tel: (0411)8368-6882 Fax: (0411)8369-0822

Tsurong Xiamen Xiangyu Trading Co., Ltd.
14G, International Bank BLDG., No.8 Lujiang Road,
Xiamen, 361001, China
Tel: (0592)226-1398 Fax: (0592)226-1399

Toshiba Electronics Korea Corporation

Seoul Head Office
891, Samsung Life Insurance Daechi Tower 20F, Daechi-dong,
Gangnam-gu, Seoul, 135-738, Korea
Tel: (02)3484-4334 Fax: (02)3484-4302

Daegu Office
16F, Hosoo Bldg. 50-3 Dongin-Dong 2(i)-GA,
Jung-gu, Daegu, Korea 700-732
Tel: (053)428-7610 Fax: (053)428-7617

Toshiba Electronics Taiwan Corporation

Taipei Head Office
10F, No.10, Sec.3, Minsheng E.Rd., Taipei City 10480, Taiwan
Tel: (02)2508-9988 Fax: (02)2508-9999

Kaohsiung Office
16F-A, Chung-Cheng Building, 2, Chung-Cheng 3Road,
Kaohsiung, 80027, Taiwan
Tel: (07)237-0826 Fax: (07)236-0046

The information contained herein is subject to change without notice.

TOSHIBA is continually working to improve the quality and reliability of its products. Nevertheless, semiconductor devices in general can malfunction or fail due to their inherent electrical sensitivity and vulnerability to physical stress. It is the responsibility of the buyer, when utilizing TOSHIBA products, to comply with the standards of safety in making a safe design for the entire system, and to avoid situations in which a malfunction or failure of such TOSHIBA products could cause loss of human life, bodily injury or damage to property. In developing your designs, please ensure that TOSHIBA products are used within specified operating ranges as set forth in the most recent TOSHIBA products specifications. Also, please keep in mind the precautions and conditions set forth in the "Handling Guide for Semiconductor Devices," or "TOSHIBA Semiconductor Reliability Handbook" etc.

The TOSHIBA products listed in this document are intended for usage in general electronics applications (computer, personal equipment, office equipment, measuring equipment, industrial robotics, domestic appliances, etc.). These TOSHIBA products are neither intended nor warranted for usage in equipment that requires extraordinarily high quality and/or reliability or a malfunction or failure of which may cause loss of human life or bodily injury ("Unintended Usage"). Unintended Usage include atomic energy control instruments, airplane or spaceship instruments, transportation instruments, traffic signal instruments, combustion control instruments, medical instruments, all types of safety devices, etc. Unintended Usage of TOSHIBA products listed in this document shall be made at the customer's own risk.

The products described in this document shall not be used or embedded to any downstream products of which manufacture, use and/or sale are prohibited under any applicable laws and regulations.

The information contained herein is presented only as a guide for the applications of our products. No responsibility is assumed by TOSHIBA for any infringements of patents or other rights of the third parties which may result from its use. No license is granted by implication or otherwise under any patents or other rights of TOSHIBA or the third parties.

Please contact your sales representative for product-by-product details in this document regarding RoHS compatibility. Please use these products in this document in compliance with all applicable laws and regulations that regulate the inclusion or use of controlled substances. Toshiba assumes no liability for damage or losses occurring as a result of noncompliance with applicable laws and regulations.

TOSHIBA

TOSHIBA CORPORATION
Semiconductor Company

Website: <http://www.semicon.toshiba.co.jp/eng>

© 2009 TOSHIBA CORPORATION

Previous edition: BCE0010E
2009-3(2k)PC-DQ