

GD4066B

QUAD BILATERAL SWITCHES

DESCRIPTION — The 4066B has four independent bilateral analog switches (transmission gates). Each switch has two Input/Output Terminals (Y_n , Z_n) and an active HIGH Enable Input (E_n). A HIGH on the Enable Input establishes a low impedance bidirectional path between Y_n and Z_n (ON condition). A LOW on the Enable Input disables the switch; high impedance between Y_n and Z_n (OFF condition).

- DIGITAL OR ANALOG SIGNAL SWITCHING
- INDIVIDUAL ENABLE INPUTS (ACTIVE HIGH)

PIN NAMES

E_0 – E_3 Enable Inputs
 Y_0 – Y_3 Input/Output Terminals
 Z_0 – Z_3 Input/Output Terminals

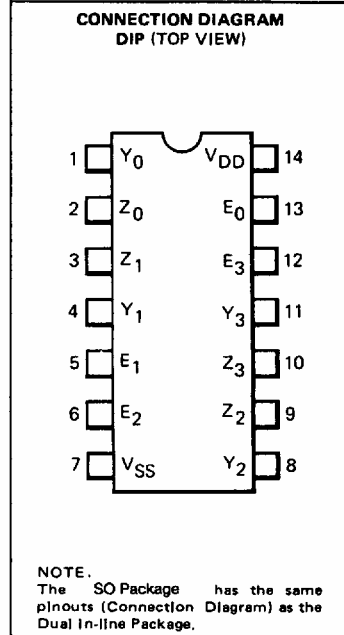
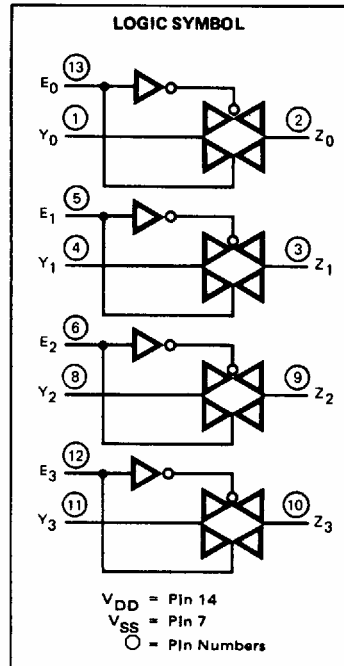
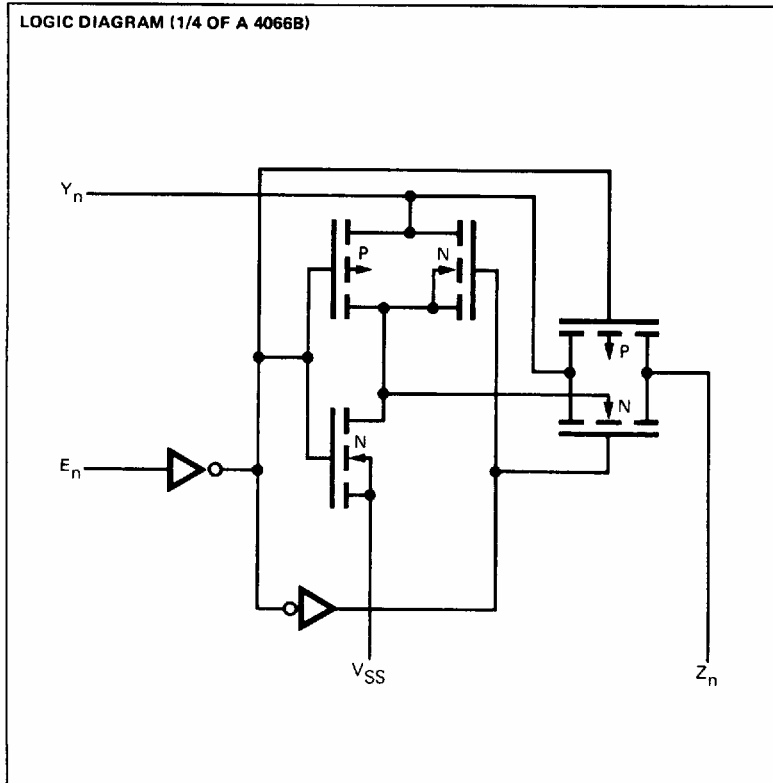

DC CHARACTERISTICS: V_{DD} as shown, $V_{SS} = 0$ V (See Note 1)

SYMBOL	PARAMETER		LIMITS									UNITS	TEMP	TEST CONDITIONS
			$V_{DD} = 5$ V			$V_{DD} = 10$ V			$V_{DD} = 15$ V					
			MIN	TYP	MAX	MIN	TYP	MAX	MIN	TYP	MAX			
R_{ON}	ON Resistance	XC	190	900		100	450		80	250	Ω	MIN 25°C MAX	$E_n = V_{DD}$ $R_L = 10$ k Ω to $V_{DD}/2$ $V_{is} = V_{DD}$ to V_{SS}	
			270	1000		120	500		80	280				
	XM	160	850		85	400		60	220	Ω	MIN. 25°C MAX			
		270	1000		120	500		80	280					
			360	1150		190	550		145	320				
ΔR_{ON}	"Δ" ON Resistance Between Any Two Channels			25			10			5		Ω	25°C	$E_n = V_{DD}$ $R_L = 10$ k Ω to $V_{DD}/2$ $V_{is} = V_{DD}$ or V_{SS}
I_Z	OFF State Leakage Current	XC								± 300	μA	MIN, 25°C	$E_n = V_{SS}$ $V_{is} = V_{DD}$ or V_{SS} $V_{os} = V_{SS}$ or V_{DD}	
										± 1000		MAX		
	XM									± 100	MIN, 25°C			
										± 1000	MAX			
I_{DD}	Quiescent Power	XC		1			2			4	μA	MIN, 25°C	All inputs at V_{DD} or V_{SS}	
				7.5			15		30	MAX				
	Supply Dissipation	XM		0.25			0.5			1	μA	MIN, 25°C		
				7.5			15		30	MAX				

Notes on following page.

GS CMOS · GD4066B

AC CHARACTERISTICS AND SET-UP REQUIREMENTS: V_{DD} as shown, $V_{SS} = 0\text{ V}$, $T_A = 25^\circ\text{C}$ (See Note 3)

SYMBOL	PARAMETER	LIMITS									UNITS	TEST CONDITIONS
		$V_{DD} = 5\text{ V}$			$V_{DD} = 10\text{ V}$			$V_{DD} = 15\text{ V}$				
		MIN	TYP	MAX	MIN	TYP	MAX	MIN	TYP	MAX		
tPLH tPHL	Propagation Delay, Y_n to Z_n or Z_n to Y_n		8	45		3	30		2	20	ns	$C_L = 50\text{ pF}$, $R_L = 200\ \Omega$ to V_{SS} Input Transition Times $< 20\text{ ns}$ $E_n = V_{DD}$ $V_{is} = V_{DD}$ (square wave)
tPZL tPZH	Output Enable Time		32	125		16	60		13	50	ns	$C_L = 50\text{ pF}$, $R_L = 1\text{ k}\Omega$ to V_{SS} or V_{DD} $E_n = V_{DD}$ (square wave)
tPLZ tPHZ	Output Disable Time		380			380			400		ns	Input Transition Times $< 20\text{ ns}$ $V_{is} = V_{DD}$ or V_{SS}
	Distortion, Sine Wave Response		0.4			0.4			0.4		%	$R_L = 10\text{ k}\Omega$ Input Frequency = 1 kHz $E_n = V_{DD}$ $V_{is} = V_{DD}/2$ (sine wave) p-p
	Crosstalk Between Any Two Switches					0.9					MHz	$R_L = 1\text{ k}\Omega$ $E_A = V_{DD}$, $E_B = V_{SS}$ $V_{is} = V_{DD}/2$ (sine wave) p-p 20 Log_{10} $[V_{os}(B)/V_{is}(A)] = -50\text{ dB}$
	Crosstalk, Enable Input to Output					50					mV	Input Transition Times $< 20\text{ ns}$ $R_L(\text{OUT}) = 1\text{ k}\Omega$ $R_L(\text{IN}) = 50\ \Omega$ $E_n = V_{DD}$ (square wave)
	OFF State Feedthrough					1.25					MHz	$R_L = 1\text{ k}\Omega$, $E_n = V_{SS}$ $V_{is} = V_{DD}/2$ (sine wave) p-p $20\text{ Log}_{10}(V_{os}/V_{is}) = -50\text{ dB}$
	ON State Frequency Response					40					MHz	$R_L = 1\text{ k}\Omega$ $V_{is} = V_{DD}/2$ (sine wave) p-p $E_n = V_{DD}$, 20 Log_{10} $(V_{os}/V_{os}@ 1\text{ kHz}) = -3\text{ dB}$
f _{MAX}	Enable Input Frequency (Note 4)					10					MHz	$C_L = 50\text{ pF}$, $R_L = 1\text{ k}\Omega$ Input Transition Times $< 20\text{ ns}$ $E_n = V_{DD}$ (square wave) $V_{os} = V_{is}/2$ at DC $V_{is} = V_{DD}$
C _{is}	Input Switch Capacitance					4					pF	$V_{DD} = 10\text{ V}$ $E_n = V_{SS}$
C _{os}	Output Swtch Capacitance					4					pF	$V_{is} = \text{Open}$ 100 kHz or
C _{ios}	Feedthrough Switch Capacitance					0.2					pF	1 MHz Bridge

NOTES:

- Additional DC Characteristics are listed in this section under 4000B Series CMOS Family Characteristics.
- V_{is}/V_{os} is the voltage signal at an Input/Output Terminal (Y_n/Z_n).
- Propagation Delays and Output Transition Times are graphically described in this section under 4000B Series CMOS Family Characteristics.
- For f_{MAX}, input rise and fall times are greater than or equal to 5 ns and less than or equal to 20 ns.
- In certain applications, the current through the external load resistor (R_L) may include both V_{DD} and signal line components. To avoid drawing V_{DD} current when switch current flows into terminals 1, 4, 8, or 11 the voltage drop across the bidirectional switch must not exceed 0.5 V at $T_A < 25^\circ\text{C}$, or 0.3 V at $T_A > 25^\circ\text{C}$. No V_{DD} current will flow through R_L if the switch current flows into terminals 2, 3, 9, or 10.

This datasheet has been downloaded from:

www.DatasheetCatalog.com

Datasheets for electronic components.