

TFT-LCD DC-DC Converter with Operational Amplifiers

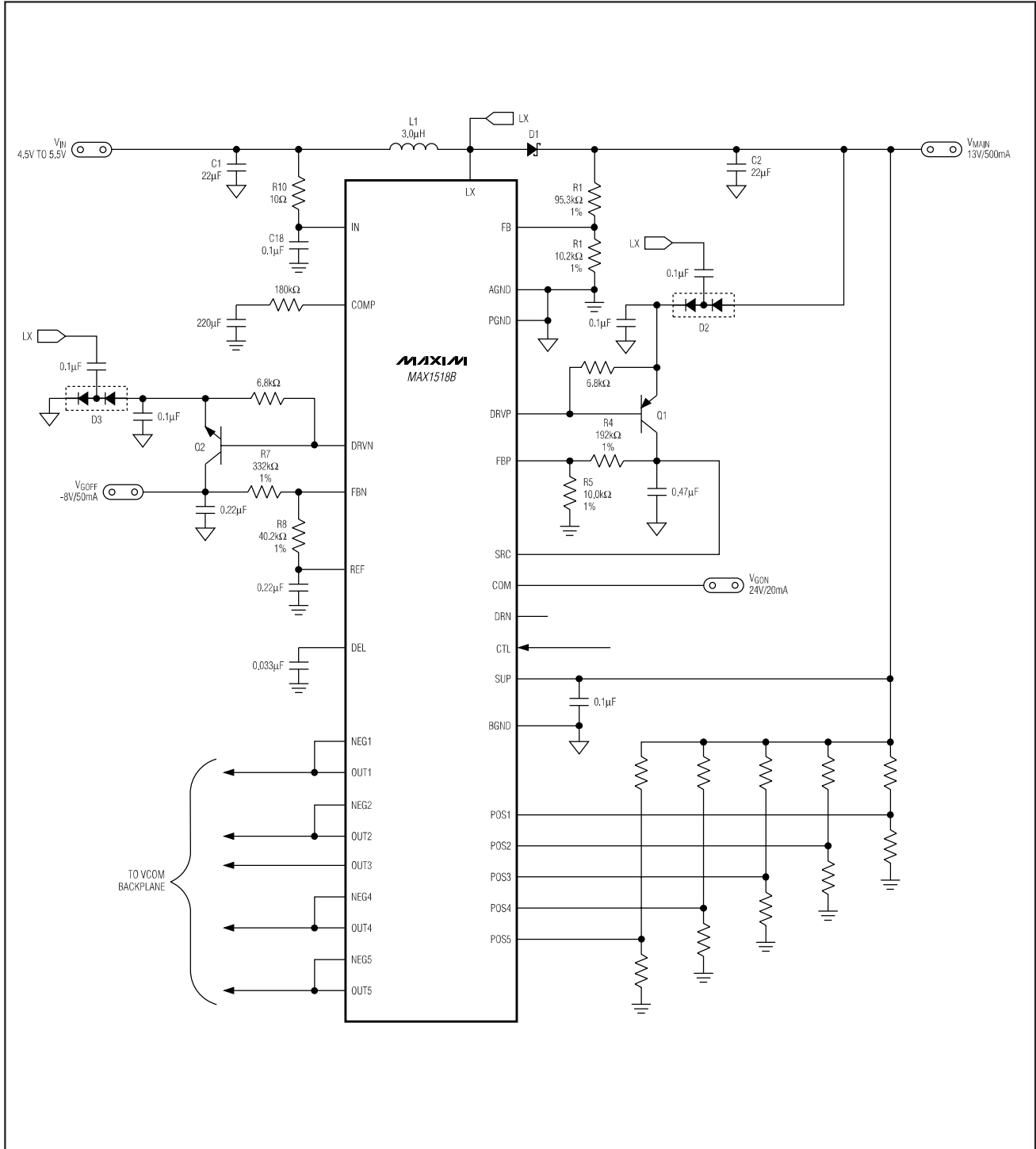

Figure 1. Typical Operating Circuit