

2-1-2 Transistors for SMPS

■ Transistors for DC-DC Converter

Part No.	V <sub>CB0</sub> (V)	V <sub>CEO</sub> (V)	I <sub>c</sub> (A)	P <sub>c</sub> (W)	Package	Fig. No.
2SC5370	60	40	12	30	TO-220F	1
2SC4024	100	50	10	35	TO-220F	
2SC4131			15	60	TO-3PF	2
2SC4153	200	120	7	30	TO-220F	
2SC3834				50	TO-220	
2SC3835				70	TO-3P	

■ Transistors for AC100V Input

Part No.	V <sub>CB0</sub> (V)	V <sub>CEO</sub> (V)	I <sub>c</sub> (A)	P <sub>c</sub> (W)	Package	Fig. No.	
2SC5271	250	200	5	30	TO-220F	1	
2SC4073	500	400	5	30	TO-220F		
2SC4418				30	TO-220F		
2SC4662				30	TO-220F		
2SC3890			7	30	TO-220F		
2SC4130				30	TO-220F		
2SC3832			50	TO-220	3		
2SC4296			75	TO-3PF	2		
2SC4138			10	80	TO-3P		4
2SC4297			75	TO-3PF	2		
2SC3833			12	100	TO-3P		4
2SC5071				100	TO-3P		
2SC4298			80	TO-3PF	2		
2SC4139			15	120	TO-3P		4
2SC4434				120	TO-3P		
2SC4140			18	130	TO-3P		
2SC5130	600	400	5	30	TO-220F	1	
2SC4546			7	30	TO-220F		
2SC4907	500	6	30	TO-220F	3		
2SC3830			50	TO-220			
2SC3831			10	100		TO-3P	
2SC5249	600	3	35	TO-220F	1		

■ Transistors for AC200V Input

Part No.	V <sub>CB0</sub> (V)	V <sub>CEO</sub> (V)	I <sub>c</sub> (A)	P <sub>c</sub> (W)	Package	Fig. No.		
2SC4517	900	550	3	30	TO-220F	1		
2SC5239				50	TO-220	3		
2SC4518			5	35	TO-220F	1		
2SC5287				80	TO-3P	4		
2SC4557				80	TO-3PF	2		
2SC3927			10	120	TO-3P	4		
2SC5586			600	5	70	TO-3PF	2	
2SC4706				14	130	TO-3P	4	
2SC4908			800	550	3	35	TO-220F	1
2SC4304						35	TO-220F	
2SC4020						50	TO-220	3
2SC4445					70	60	TO-3PF	2
2SC4299						70	TO-3PF	
2SC3678						80	TO-3P	
2SC4300					5	75	TO-3PF	2
2SC3679	100	TO-3P				4		
2SC4301	7	80			TO-3PF	2		
2SC3680		120			TO-3P	4		
2SC4517A	1000	550			3	30	TO-220F	1
2SC4518A					5	35	TO-220F	
2SC5002	1500	800			7	80	TO-3PF	2
2SC5124					10	100	TO-3PF	

External Dimensions

• No. 1 (TO-220F)

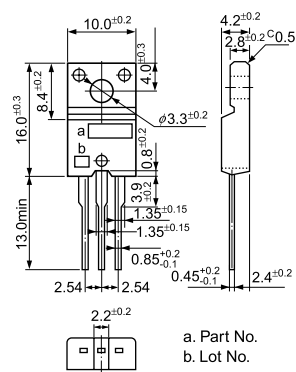

• No. 2 (TO-3PF)

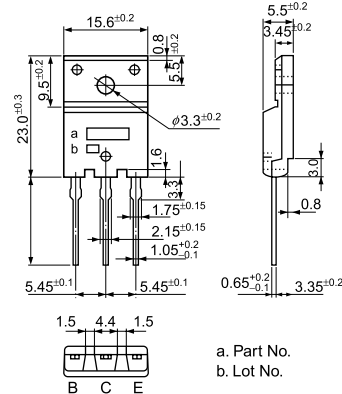

• No. 3 (TO-220)

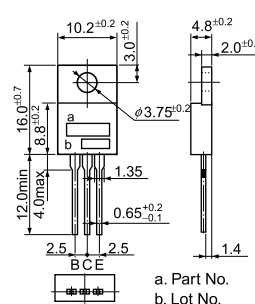

• No. 4 (TO-3P)

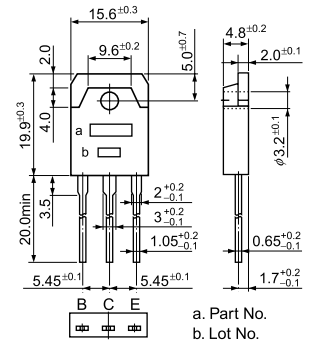

(unit: mm)