



February 2016

KSP2907A PNP General-Purpose Amplifier

Features

- Collector-Emitter Voltage: $V_{CEO} = -60\text{ V}$
- Suffix “-C” means a Center Collector (1. Emitter 2. Collector 3. Base)

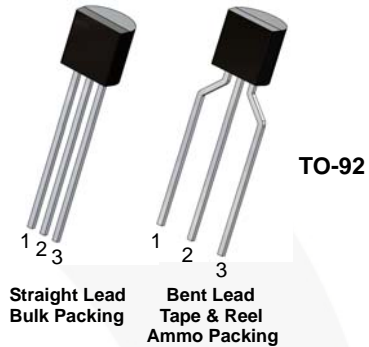

KSP2907A: 1. Emitter 2. Base 3. Collector
 KSP2907AC: 1. Emitter 2. Collector 3. Base

Ordering Information⁽¹⁾

Part Number	Marking	Package	Packing Method
KSP2907ABU	KSP2907A	TO-92 3L	Bulk
KSP2907ATA	KSP2907A	TO-92 3L	Ammo
KSP2907ATF	KSP2907A	TO-92 3L	Tape and Reel
KSP2907ACTA	KSP2907AC	TO-92 3L	Ammo

Note:

1. Affix “-C-” means center collector pin. Suffix “-BU” means bulk packing, and straight lead form. Suffix “-TF” means tape & reel packing, and 0.200 in-line spacing lead form. Suffix “-TA” means ammo packing, and 0.200 in-line spacing lead form.

Absolute Maximum Ratings

Stresses exceeding the absolute maximum ratings may damage the device. The device may not function or be operable above the recommended operating conditions and stressing the parts to these levels is not recommended. In addition, extended exposure to stresses above the recommended operating conditions may affect device reliability. The absolute maximum ratings are stress ratings only. Values are at $T_A = 25^\circ\text{C}$ unless otherwise noted.

Symbol	Parameter	Value	Unit
V_{CBO}	Collector-Base Voltage	-60	V
V_{CEO}	Collector-Emitter Voltage	-60	V
V_{EBO}	Emitter-Base Voltage	-5	V
I_C	Collector Current	-600	mA
T_J	Junction Temperature	150	$^\circ\text{C}$
T_{STG}	Storage Temperature	-55 to +150	$^\circ\text{C}$

Thermal Characteristics

Values are at $T_A = 25^\circ\text{C}$ unless otherwise noted.

Symbol	Parameter	Max.	Unit
P_D	Power Dissipation by $R_{\theta JA}$	625	mW
	Derate Above 25°C	5	mW/ $^\circ\text{C}$
$R_{\theta JC}$	Thermal Resistance, Junction-to-Case ⁽²⁾	83.3	$^\circ\text{C}/\text{W}$
$R_{\theta JA}$	Thermal Resistance, Junction-to-Ambient ⁽³⁾	200	$^\circ\text{C}/\text{W}$

Notes:

- Infinite heat sink.
- PCB size: FR-4, 76 mm x 114 mm x 1.57 mm (3.0 inch x 4.5 inch x 0.062 inch) with minimum land pattern size.

Electrical Characteristics⁽⁴⁾

Values are at $T_A = 25^\circ\text{C}$ unless otherwise noted.

Symbol	Parameter	Conditions	Min.	Max.	Unit
BV_{CBO}	Collector-Base Breakdown Voltage	$I_C = -10 \mu\text{A}$, $I_E = 0$	-60		V
BV_{CEO}	Collector-Emitter Breakdown Voltage	$I_C = -10 \text{ mA}$, $I_B = 0$	-60		V
BV_{EBO}	Emitter-Base Breakdown Voltage	$I_E = -10 \mu\text{A}$, $I_C = 0$	-5.0		V
I_{CBO}	Collector Cut-Off Current	$V_{CB} = -50 \text{ V}$, $I_E = 0$		-10	nA
h_{FE}	DC Current Gain	$V_{CE} = -10 \text{ V}$, $I_C = -0.1 \text{ mA}$	75		
		$V_{CE} = -10 \text{ V}$, $I_C = -1 \text{ mA}$	100		
		$V_{CE} = -10 \text{ V}$, $I_C = -10 \text{ mA}$	100		
		$V_{CE} = -10 \text{ V}$, $I_C = -150 \text{ mA}$	100	300	
		$V_{CE} = -10 \text{ V}$, $I_C = -500 \text{ mA}$	50		
$V_{CE(sat)}$	Collector-Emitter Saturation Voltage	$I_C = -150 \text{ mA}$, $I_B = -15 \text{ mA}$		-0.4	V
		$I_C = -500 \text{ mA}$, $I_B = -50 \text{ mA}$		-1.6	
$V_{BE(sat)}$	Base-Emitter Saturation Voltage	$I_C = -150 \text{ mA}$, $I_B = -15 \text{ mA}$		-1.3	V
		$I_C = -500 \text{ mA}$, $I_B = -50 \text{ mA}$		-2.6	
C_{obo}	Output Capacitance	$V_{CB} = -10 \text{ V}$, $I_E = 0$, $f = 1.0 \text{ MHz}$		8	pF
f_T	Current Gain Bandwidth Product	$I_C = -50 \text{ mA}$, $V_{CE} = -20 \text{ V}$, $f = 100 \text{ MHz}$	200		MHz
t_{ON}	Turn-On Time	$V_{CC} = -30 \text{ V}$, $I_C = -150 \text{ mA}$, $I_{B1} = -15 \text{ mA}$		45	ns
t_{OFF}	Turn-Off Time	$V_{CC} = -6 \text{ V}$, $I_C = -150 \text{ mA}$, $I_{B1} = I_{B2} = -15 \text{ mA}$		100	ns

Note:

- DC items are tested by pulse test: pulse width $\leq 300 \mu\text{s}$, duty cycle $\leq 2\%$