



STB18NM80, STF18NM80, STP18NM80, STW18NM80

N-channel 800 V, 0.25 Ω , 17 A, MDmesh™ Power MOSFET
in D²PAK, TO-220FP, TO-220 and TO-247 packages

Datasheet — production data

Features

Order codes	V _{DSS}	R _{DS(on) max}	I _D
STB18NM80	800 V	< 0.295 Ω	17 A
STF18NM80	800 V	< 0.295 Ω	17 A ⁽¹⁾
STP18NM80	800 V	< 0.295 Ω	17 A
STW18NM80	800 V	< 0.295 Ω	17 A

1. Limited only by maximum temperature allowed

- 100% avalanche tested
- Low input capacitance and gate charge
- Low gate input resistance

Application

- Switching applications

Description

These N-channel Power MOSFETs are developed using STMicroelectronics' revolutionary MDmesh™ technology, which associates the multiple drain process with the company's PowerMESH™ horizontal layout. These devices offer extremely low on-resistance, high dv/dt and excellent avalanche characteristics. Utilizing ST's proprietary strip technique, these Power MOSFETs boast an overall dynamic performance which is superior to similar products on the market.

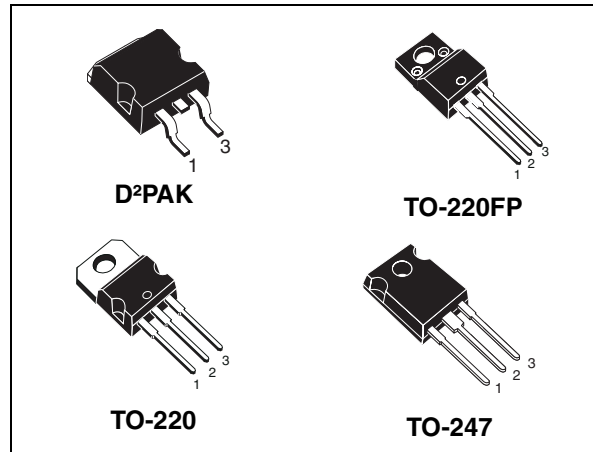
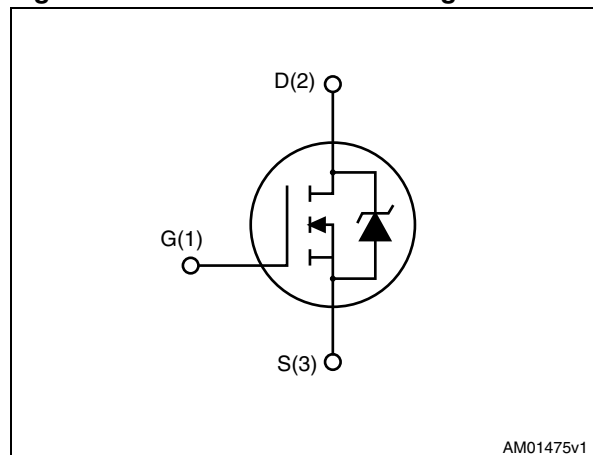

Figure 1. Internal schematic diagram



AM01475v1

Table 1. Device summary

Order codes	Marking	Package	Packaging
STB18NM80	18NM80	D ² PAK	Tape and reel
STF18NM80		TO-220FP	Tube
STP18NM80		TO-220	
STW18NM80		TO-247	

Contents

1	Electrical ratings	3
2	Electrical characteristics	4
2.1	Electrical characteristics (curves)	6
3	Test circuits	9
4	Package mechanical data	10
5	Packaging mechanical data	18
6	Revision history	20



1 Electrical ratings

Table 2. Absolute maximum ratings

Symbol	Parameter	Value				Unit
		TO-220	D ² PAK	TO-247	TO-220FP	
V _{DS}	Drain-source voltage	800				V
V _{GS}	Gate-source voltage	± 30				V
I _D	Drain current (continuous) at T _C = 25 °C	17		17 ⁽¹⁾		A
I _D	Drain current (continuous) at T _C = 100 °C	10.71		10.71 ⁽¹⁾		A
I _{DM} ⁽²⁾	Drain current (pulsed)	68		68 ⁽¹⁾		A
P _{TOT}	Total dissipation at T _C = 25 °C	190		40		W
V _{ISO}	Insulation withstand voltage (RMS) from all three leads to external heat sink (t = 1 s; T _C = 25 °C)	2500				V
T _{stg}	Storage temperature	-65 to 150				°C
T _j	Max. operating junction temperature	150				°C

1. Limited only by maximum temperature allowed
2. Pulse width limited by safe operating area

Table 3. Thermal data

Symbol	Parameter	Value				Unit
		TO-220	D ² PAK	TO-247	TO-220FP	
R _{thj-case}	Thermal resistance junction-case	0.66		3.13		°C/W
R _{thj-amb}	Thermal resistance junction-amb	62.5		50	62.5	°C/W
R _{thj-pcb}	Thermal resistance junction-pcb		30			°C/W
T _l	Maximum lead temperature for soldering purpose	300				°C

Table 4. Avalanche characteristics

Symbol	Parameter	Max value	Unit
I _{AS}	Avalanche current, repetitive or not-repetitive (pulse width limited by T _j max)	4	A
E _{AS}	Single pulse avalanche energy (starting T _j = 25 °C, I _D = I _{AS} , V _{DD} = 50 V)	600	mJ

2 Electrical characteristics

($T_{CASE} = 25\text{ °C}$ unless otherwise specified)

Table 5. On/off states

Symbol	Parameter	Test conditions	Min.	Typ.	Max.	Unit
$V_{(BR)DSS}$	Drain-source breakdown voltage	$I_D = 1\text{ mA}$, $V_{GS} = 0$	800			V
I_{DSS}	Zero gate voltage drain current ($V_{GS} = 0$)	$V_{DS} = 800\text{ V}$, $V_{DS} = 800\text{ V}$, $T_C = 125\text{ °C}$			10 100	μA μA
I_{GSS}	Gate body leakage current ($V_{DS} = 0$)	$V_{GS} = \pm 30\text{ V}$			± 100	nA
$V_{GS(th)}$	Gate threshold voltage	$V_{DS} = V_{GS}$, $I_D = 250\text{ }\mu\text{A}$	3	4	5	V
$R_{DS(on)}$	Static drain-source on-resistance	$V_{GS} = 10\text{ V}$, $I_D = 8.5\text{ A}$		0.25	0.295	Ω

Table 6. Dynamic

Symbol	Parameter	Test conditions	Min.	Typ.	Max.	Unit
$g_{fs}^{(1)}$	Forward transconductance	$V_{DS} = 15\text{ V}$, $I_D = 8.5\text{ A}$	-	14	-	S
C_{iss} C_{oss} C_{rss}	Input capacitance Output capacitance Reverse transfer capacitance	$V_{DS} = 50\text{ V}$, $f = 1\text{ MHz}$, $V_{GS} = 0$	-	2070 210 29	-	pF pF pF
$C_{oss\text{ eq.}}^{(2)}$	Equivalent output capacitance	$V_{GS} = 0$, $V_{DS} = 0\text{ to }640\text{ V}$	-	316	-	pF
R_G	Gate input resistance	$f = 1\text{ MHz}$ Gate DC Bias = 0 Test Signal Level = 20 mV Open Drain	-	4	-	Ω
Q_g Q_{gs} Q_{gd}	Total gate charge Gate-source charge Gate-drain charge	$V_{DD} = 640\text{ V}$, $I_D = 17\text{ A}$ $V_{GS} = 10\text{ V}$ (see Figure 17)	-	70 13 40	-	nC nC nC

1. Pulsed: pulse duration = 300 μs , duty cycle 1.5%
2. $C_{oss\text{ eq.}}$ is defined as a constant equivalent capacitance giving the same charging time as C_{oss} when V_{DS} increases from 0 to 80% V_{DSS}

Table 7. Switching times

Symbol	Parameter	Test conditions	Min.	Typ.	Max.	Unit
$t_{d(on)}$	Turn-on delay time	$V_{DD} = 400\text{ V}$, $I_D = 8.5\text{ A}$,		18		ns
t_r	Rise time	$R_G = 4.7\ \Omega$, $V_{GS} = 10\text{ V}$	-	28	-	ns
$t_{d(off)}$	Turn-off delay time	(see Figure 16 and		96		ns
t_f	Fall time	Figure 21)		50		ns

Table 8. Source drain diode

Symbol	Parameter	Test conditions	Min.	Typ.	Max.	Unit
I_{SD}	Source-drain current		-		17	A
$I_{SDM}^{(1)}$	Source-drain current (pulsed)		-		68	A
$V_{SD}^{(2)}$	Forward on voltage	$I_{SD} = 17\text{ A}$, $V_{GS} = 0$	-		1.6	V
t_{rr}	Reverse recovery time	$I_{SD} = 17\text{ A}$, $di/dt = 100$	-	618		ns
Q_{rr}	Reverse recovery charge	$A/\mu\text{s}$, $V_{DD} = 100\text{ V}$,		9.6		μC
I_{RRM}	Reverse recovery current	(see Figure 18)		31.2		A
t_{rr}	Reverse recovery time	$I_{SD} = 17\text{ A}$,	-	822		ns
Q_{rr}	Reverse recovery charge	$di/dt = 100\text{ A}/\mu\text{s}$,		13		μC
I_{RRM}	Reverse recovery current	$V_{DD} = 100\text{ V}$, $T_j = 150^\circ\text{C}$		31.8		A
		(see Figure 18)				

1. Pulse width limited by safe operating area

2. Pulsed: pulse duration = 300 μs , duty cycle 1.5%

2.1 Electrical characteristics (curves)

Figure 2. Safe operating area for TO-220, D²PAK

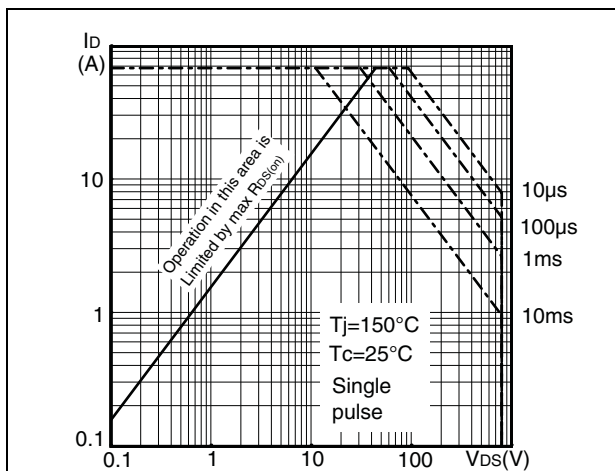

Figure 3. Thermal impedance for TO-220, D²PAK

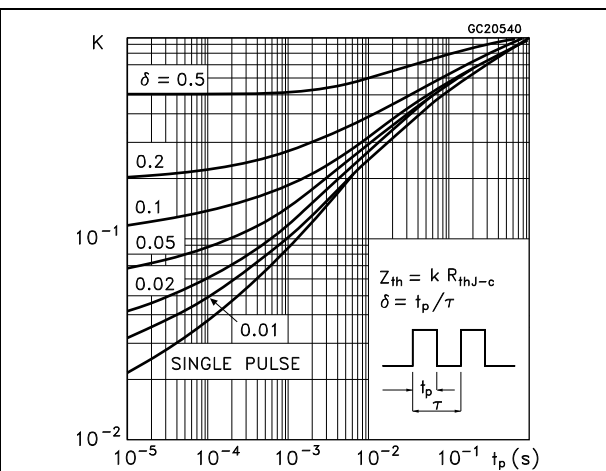

Figure 4. Safe operating area for TO-247

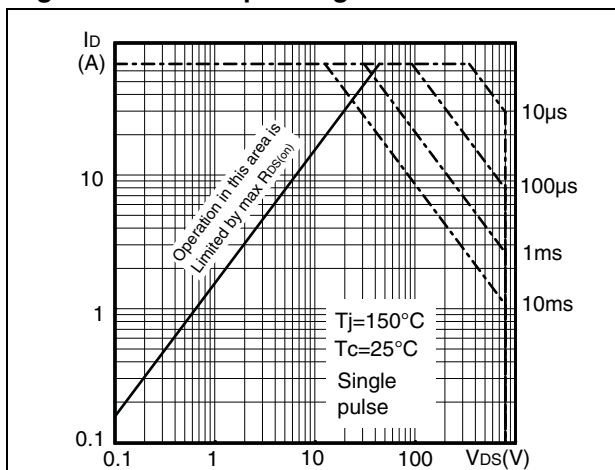

Figure 5. Thermal impedance for TO-247

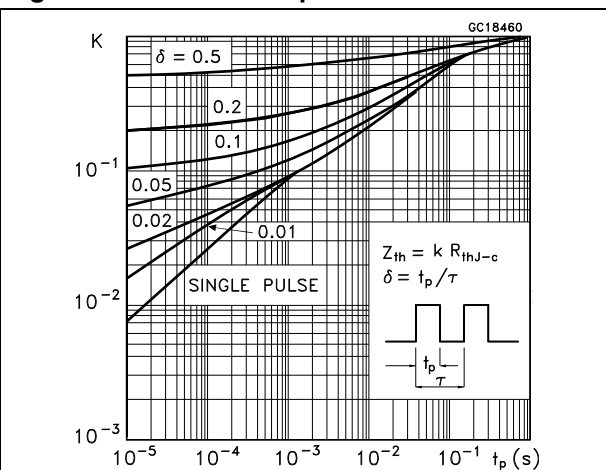

Figure 6. Safe operating area for TO-220FP

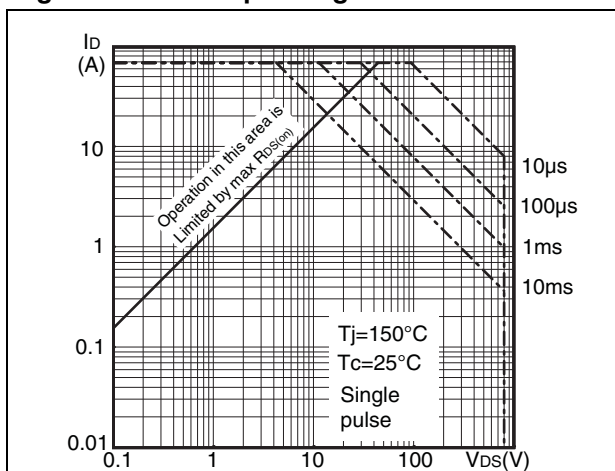

Figure 7. Thermal impedance for TO-220FP

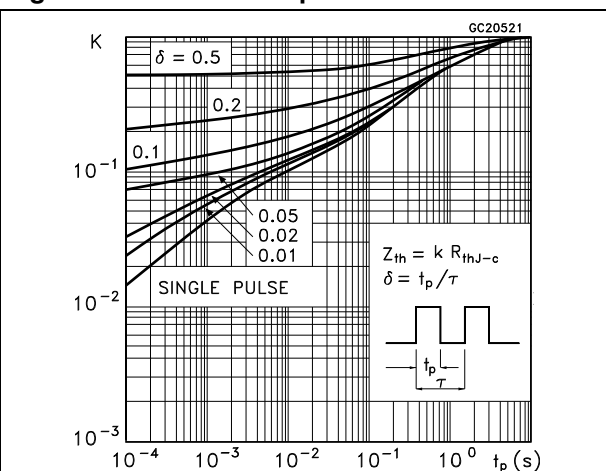

Figure 8. Output characteristics

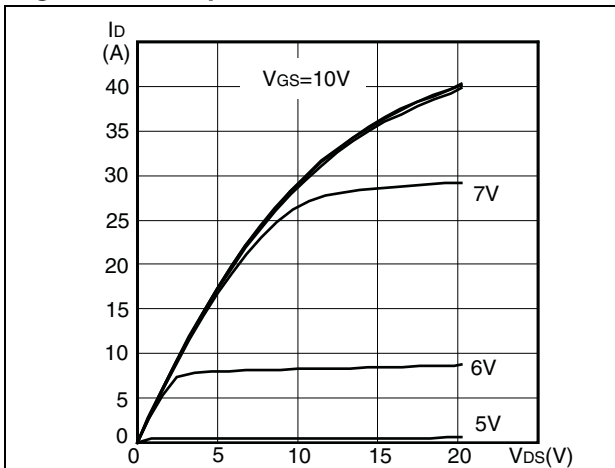

Figure 9. Transfer characteristics

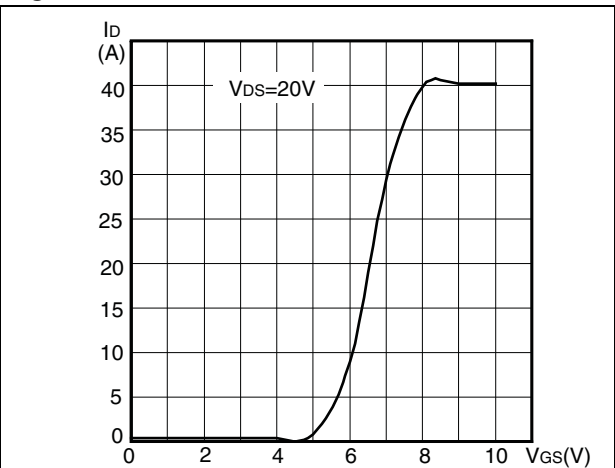

Figure 10. Normalized $B_{V_{DS}}$ vs temperature

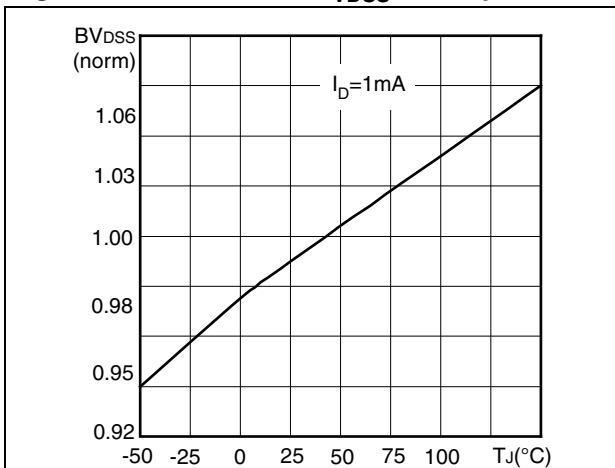

Figure 11. Static drain-source on-resistance

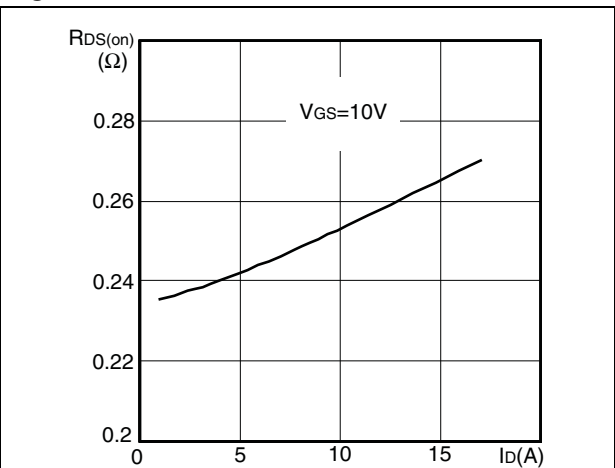

Figure 12. Gate charge vs gate-source voltage

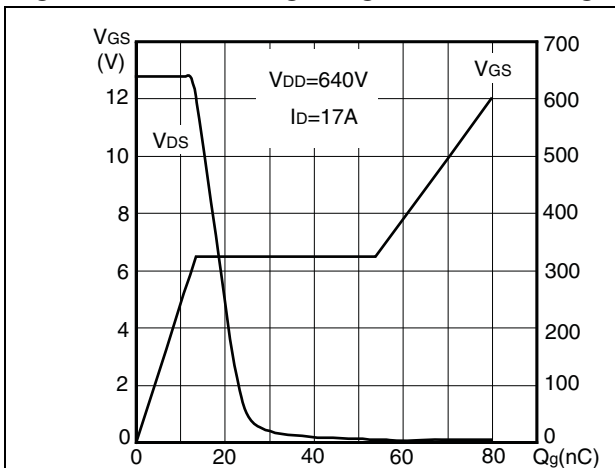

Figure 13. Capacitance variations

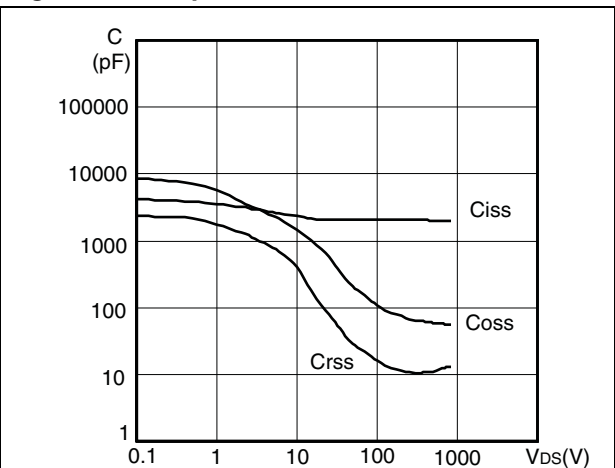

Figure 14. Normalized gate threshold voltage vs temperature

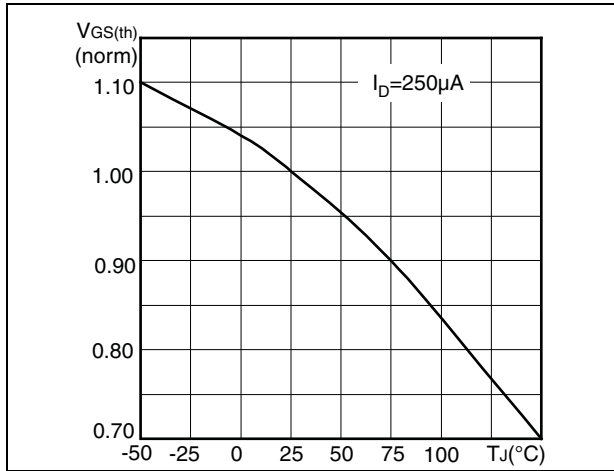
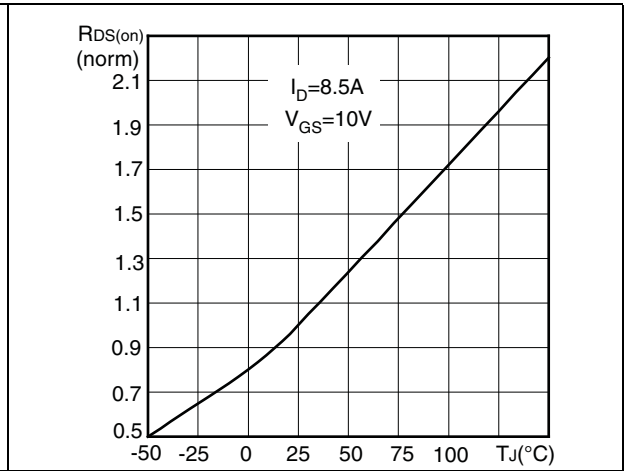

Figure 15. Normalized on-resistance vs temperature



3 Test circuits

Figure 16. Switching times test circuit for resistive load

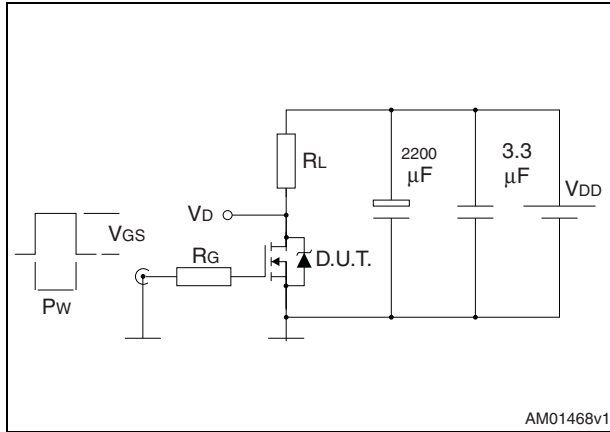

Figure 17. Gate charge test circuit

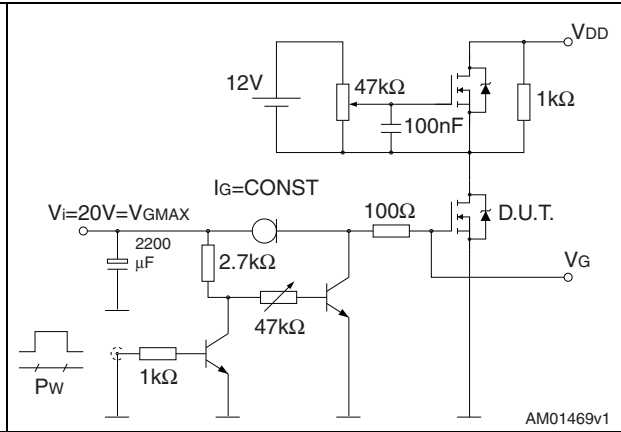

Figure 18. Test circuit for inductive load switching and diode recovery times

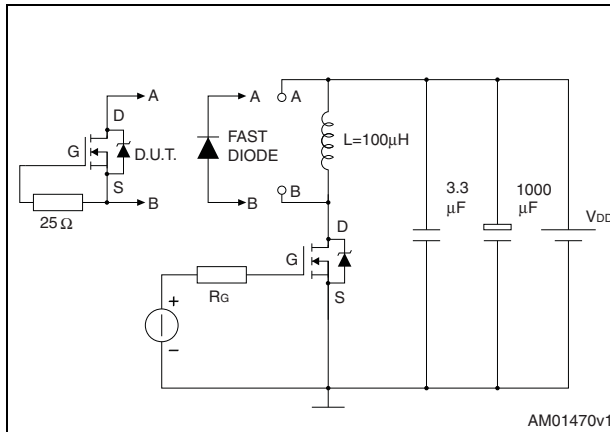

Figure 19. Unclamped inductive load test circuit

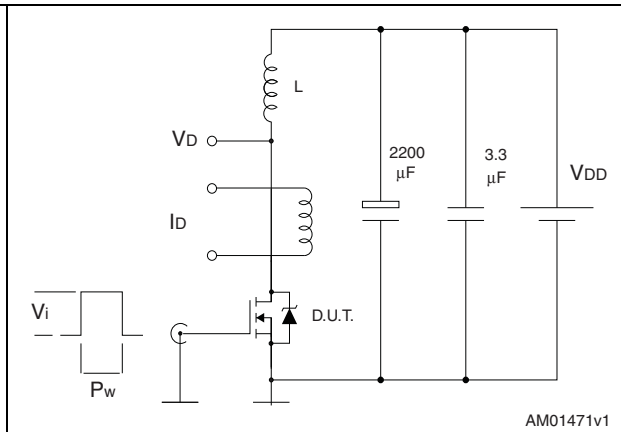

Figure 20. Unclamped inductive waveform

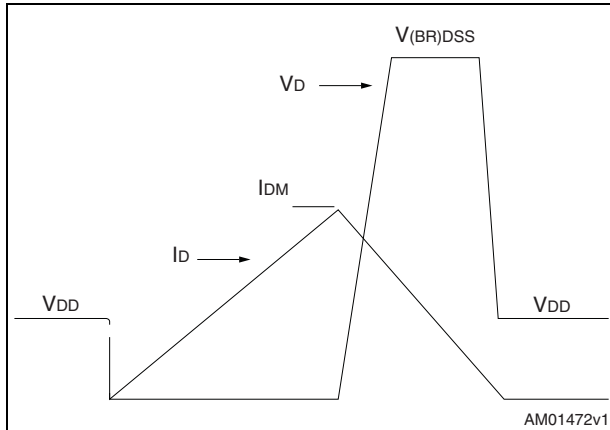
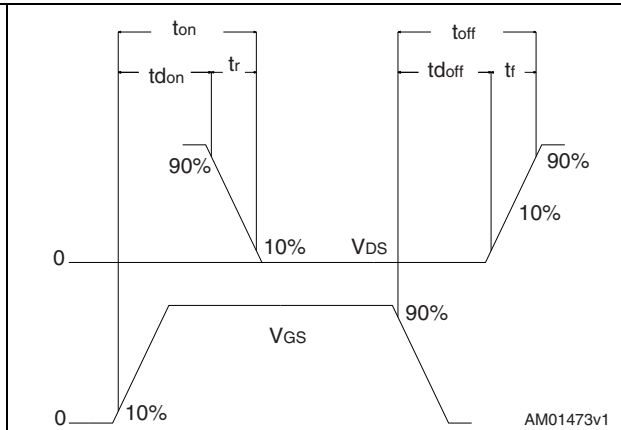

Figure 21. Switching time waveform



4 Package mechanical data

In order to meet environmental requirements, ST offers these devices in different grades of ECOPACK[®] packages, depending on their level of environmental compliance. ECOPACK[®] specifications, grade definitions and product status are available at: www.st.com. ECOPACK is an ST trademark.

Table 9. D²PAK (TO-263) mechanical data

Dim.	mm		
	Min.	Typ.	Max.
A	4.40		4.60
A1	0.03		0.23
b	0.70		0.93
b2	1.14		1.70
c	0.45		0.60
c2	1.23		1.36
D	8.95		9.35
D1	7.50		
E	10		10.40
E1	8.50		
e		2.54	
e1	4.88		5.28
H	15		15.85
J1	2.49		2.69
L	2.29		2.79
L1	1.27		1.40
L2	1.30		1.75
R		0.4	
V2	0°		8°

Figure 22. D²PAK (TO-263) drawing

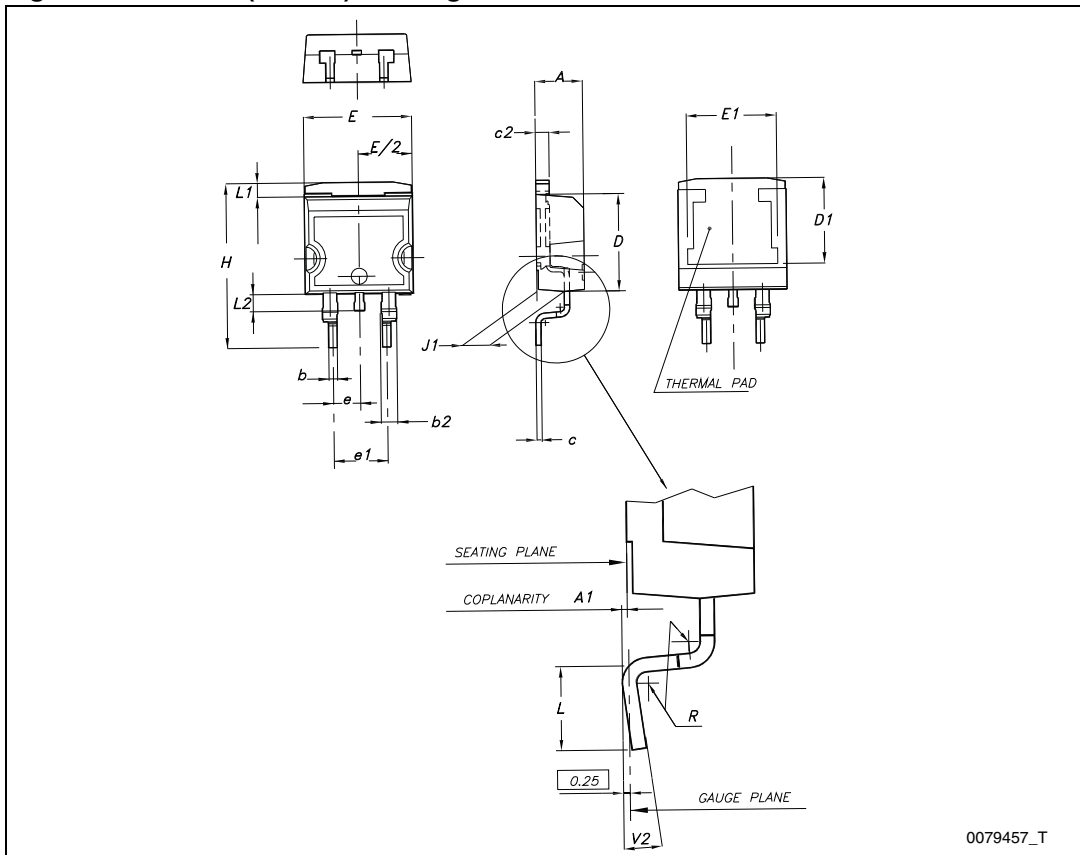
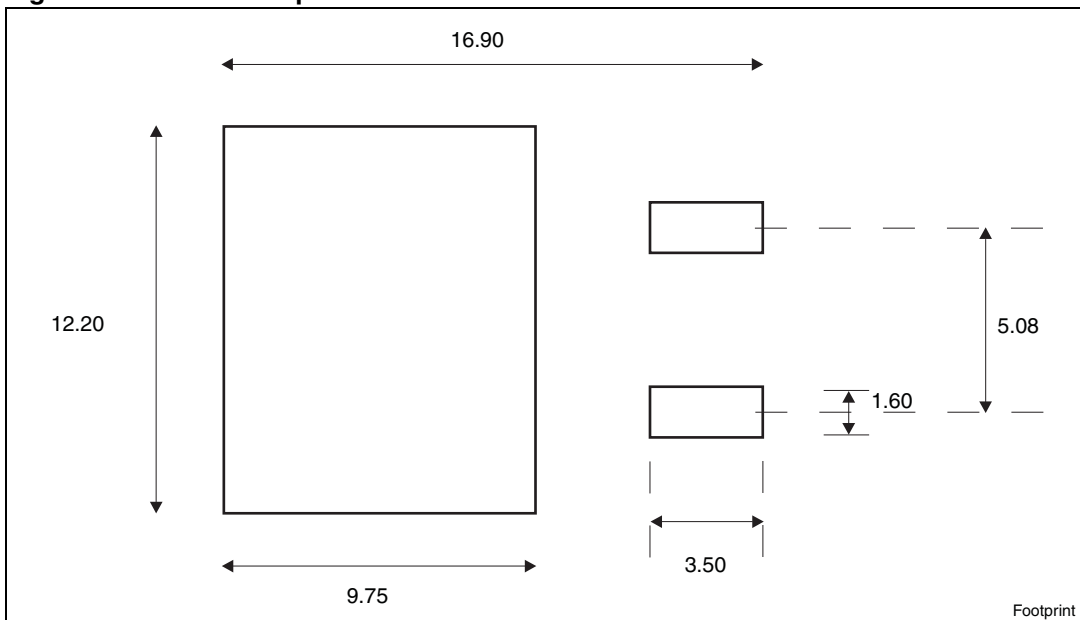

Figure 23. D²PAK footprint^(a)



a. All dimensions are in millimeters

Table 10. TO-220FP mechanical data

Dim.	mm		
	Min.	Typ.	Max.
A	4.4		4.6
B	2.5		2.7
D	2.5		2.75
E	0.45		0.7
F	0.75		1
F1	1.15		1.70
F2	1.15		1.70
G	4.95		5.2
G1	2.4		2.7
H	10		10.4
L2		16	
L3	28.6		30.6
L4	9.8		10.6
L5	2.9		3.6
L6	15.9		16.4
L7	9		9.3
Dia	3		3.2

Figure 24. TO-220FP drawing

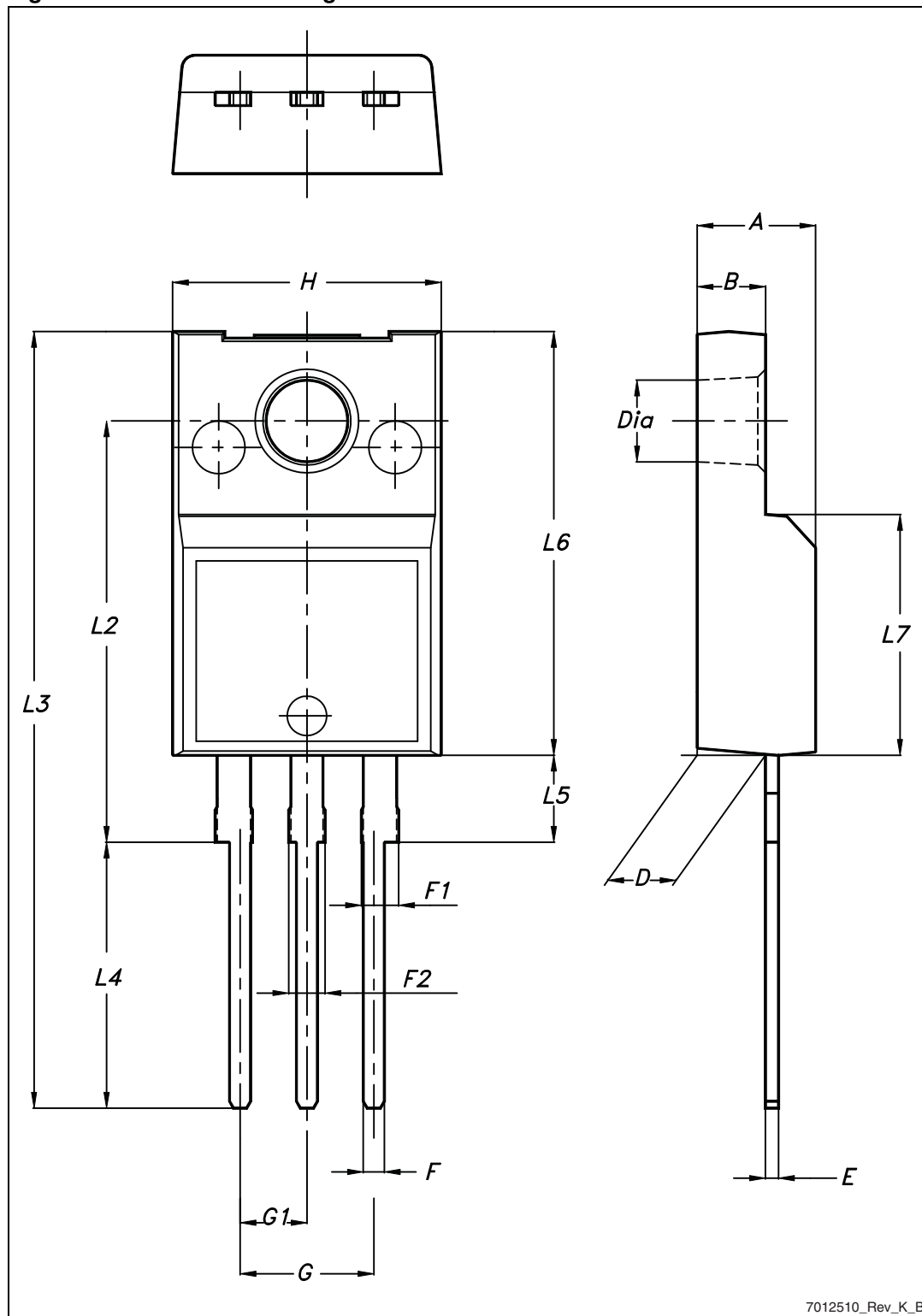

Table 11. TO-220 type A mechanical data

Dim.	mm		
	Min.	Typ.	Max.
A	4.40		4.60
b	0.61		0.88
b1	1.14		1.70
c	0.48		0.70
D	15.25		15.75
D1		1.27	
E	10		10.40
e	2.40		2.70
e1	4.95		5.15
F	1.23		1.32
H1	6.20		6.60
J1	2.40		2.72
L	13		14
L1	3.50		3.93
L20		16.40	
L30		28.90	
ØP	3.75		3.85
Q	2.65		2.95

Figure 25. TO-220 type A drawing

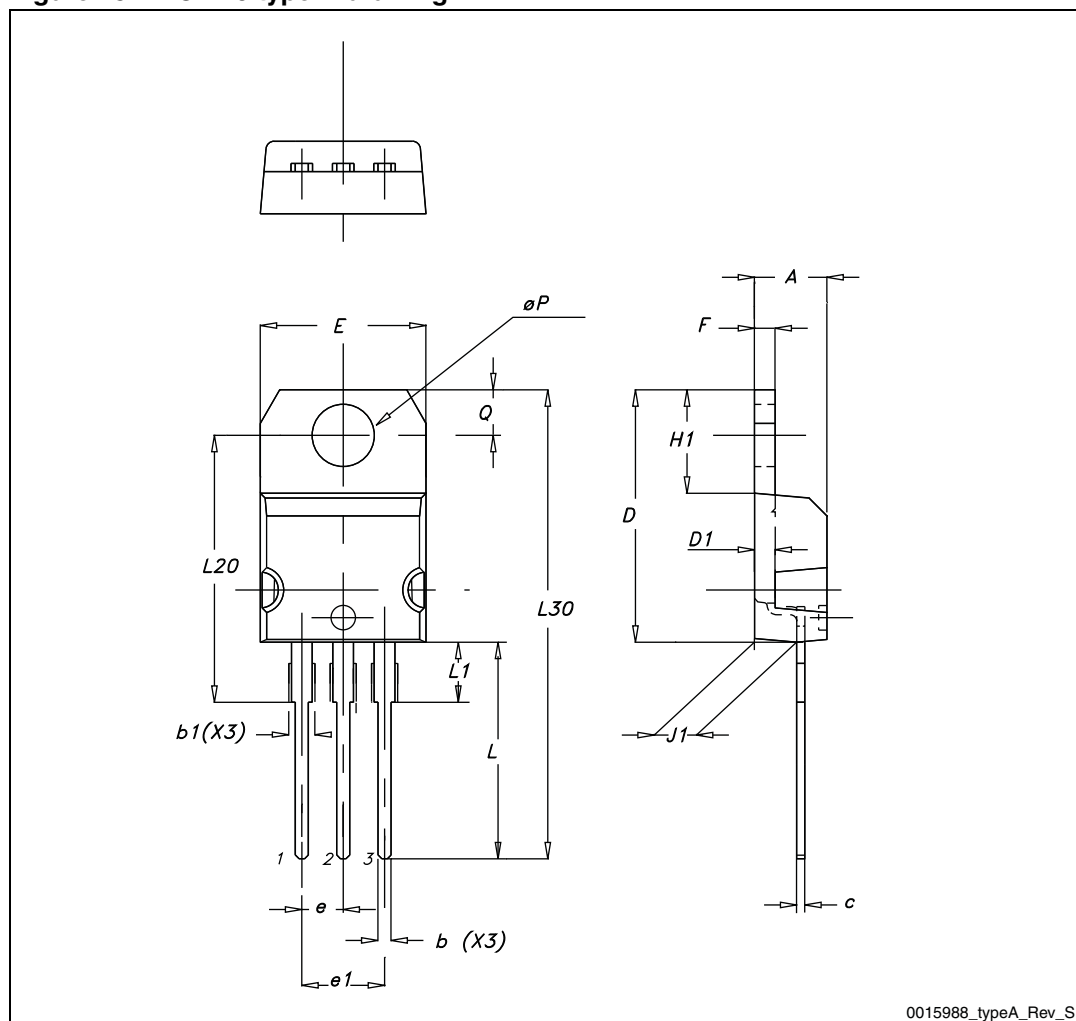
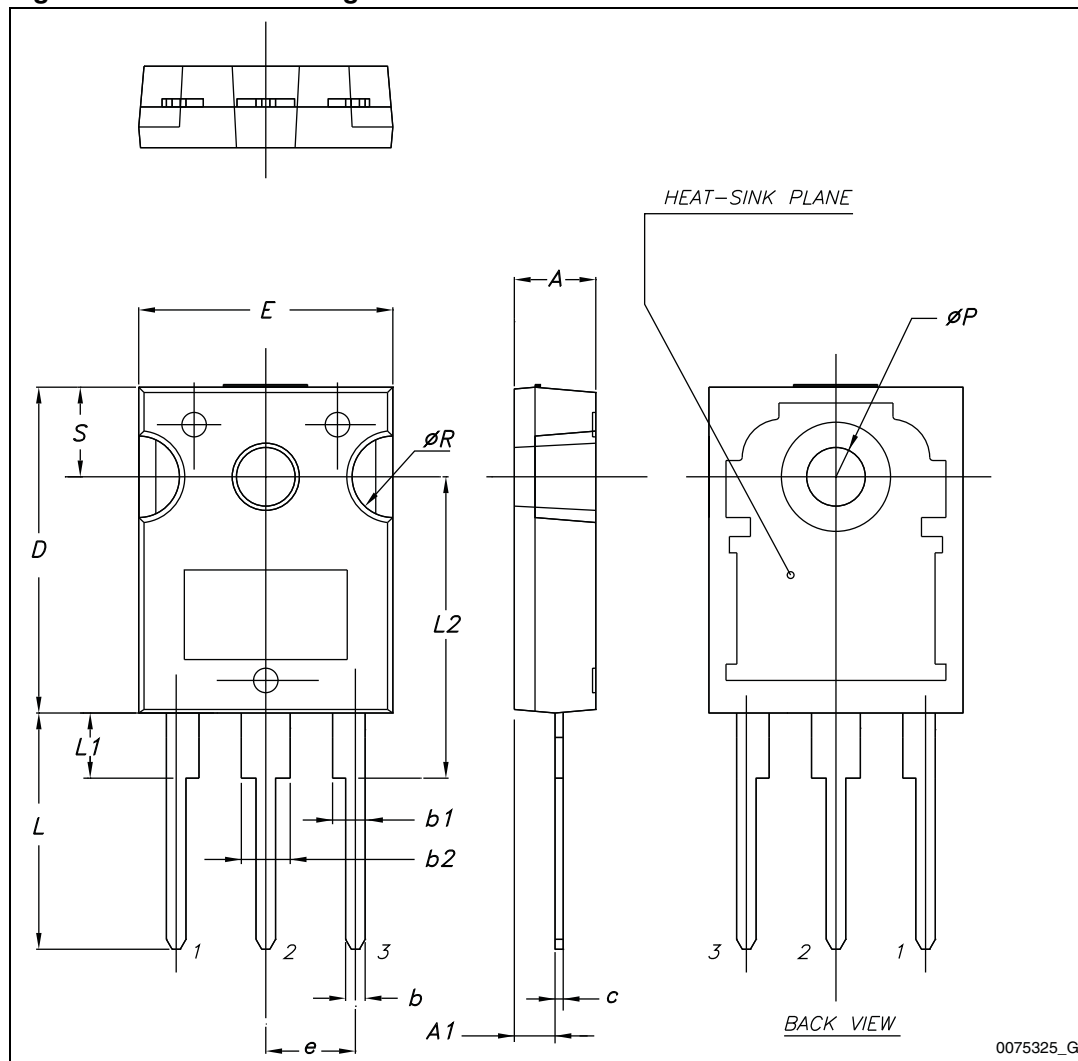

Table 12. TO-247 mechanical data

Dim.	mm.		
	Min.	Typ.	Max.
A	4.85		5.15
A1	2.20		2.60
b	1.0		1.40
b1	2.0		2.40
b2	3.0		3.40
c	0.40		0.80
D	19.85		20.15
E	15.45		15.75
e	5.30	5.45	5.60
L	14.20		14.80
L1	3.70		4.30
L2		18.50	
ØP	3.55		3.65
ØR	4.50		5.50
S	5.30	5.50	5.70

Figure 26. TO-247 drawing



5 Packaging mechanical data

Table 13. D²PAK (TO-263) tape and reel mechanical data

Tape			Reel		
Dim.	mm		Dim.	mm	
	Min.	Max.		Min.	Max.
A0	10.5	10.7	A		330
B0	15.7	15.9	B	1.5	
D	1.5	1.6	C	12.8	13.2
D1	1.59	1.61	D	20.2	
E	1.65	1.85	G	24.4	26.4
F	11.4	11.6	N	100	
K0	4.8	5.0	T		30.4
P0	3.9	4.1			
P1	11.9	12.1		Base qty	1000
P2	1.9	2.1		Bulk qty	1000
R	50				
T	0.25	0.35			
W	23.7	24.3			

Figure 27. Tape

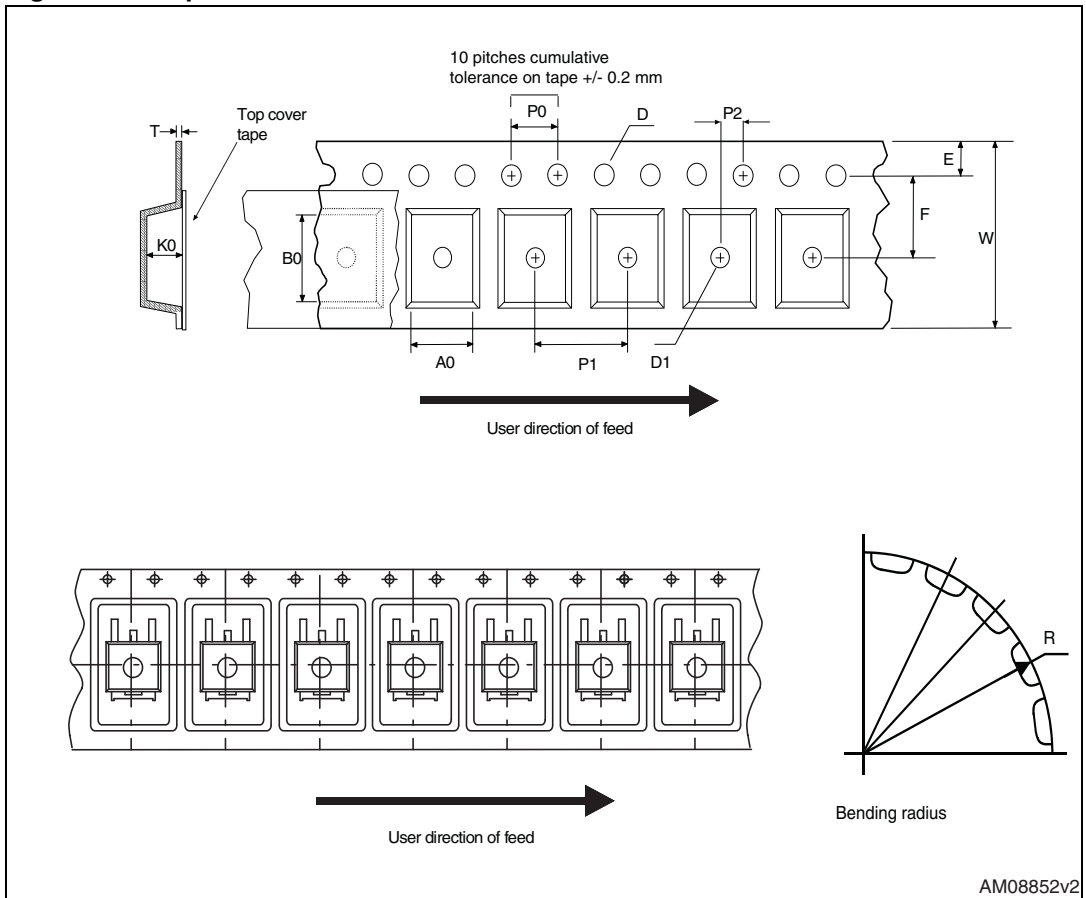
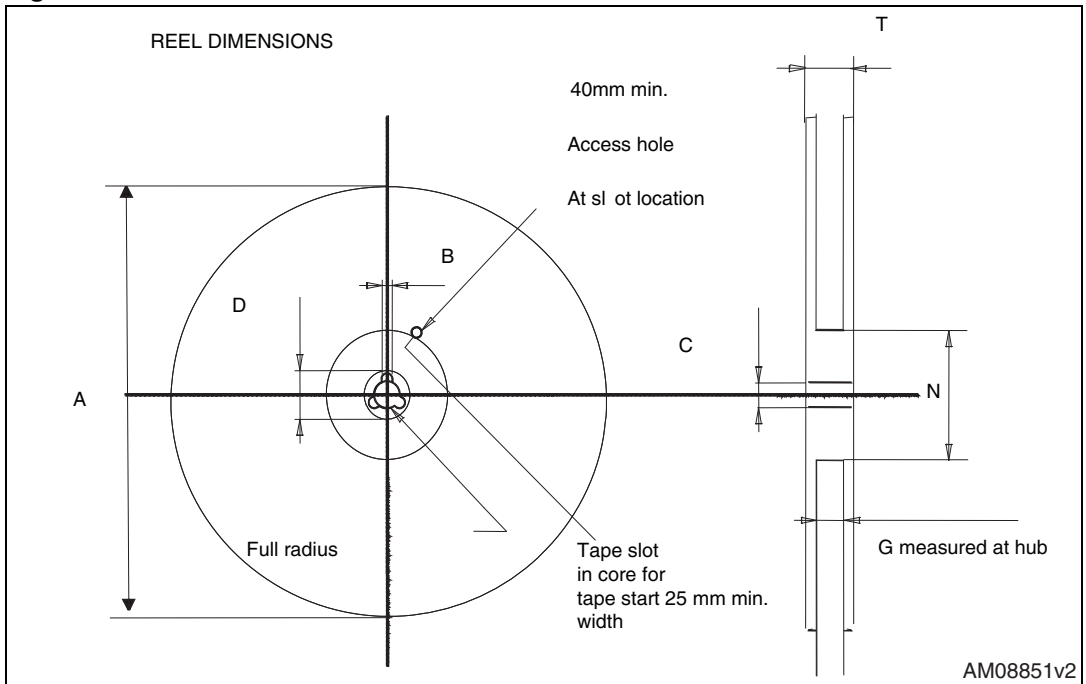

Figure 28. Reel



6 Revision history

Table 14. Document revision history

Date	Revision	Changes
25-Feb-2009	1	First release.
07-Apr-2009	2	Section 4: Package mechanical data has been modified.
20-Apr-2009	3	$R_{DS(on)}$ max value has been corrected.
09-Sep-2009	4	Document status promoted from preliminary data to datasheet.
25-May-2012	5	Figure 12: Gate charge vs gate-source voltage has been updated. Minor text changes.