

N

*Discrete POWER & Signal
Technologies*

**2N5484
2N5485
2N5486**

**MMBF5484
MMBF5485
MMBF5486**

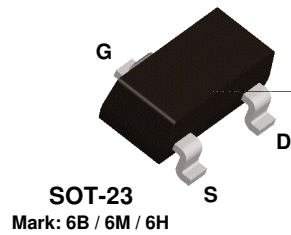
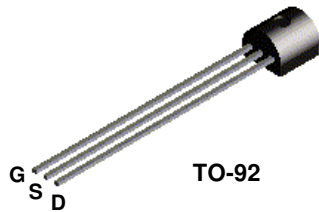

N-Channel RF Amplifier

This device is designed primarily for electronic switching applications such as low On Resistance analog switching. Sourced from Process 50.

Absolute Maximum Ratings*

TA = 25°C unless otherwise noted

Symbol	Parameter	Value	Units
V _{DG}	Drain-Gate Voltage	25	V
V _{GS}	Gate-Source Voltage	- 25	V
I _{GF}	Forward Gate Current	10	mA
T _J , T _{stg}	Operating and Storage Junction Temperature Range	-55 to +150	°C

*These ratings are limiting values above which the serviceability of any semiconductor device may be impaired.

NOTES:

- 1) These ratings are based on a maximum junction temperature of 150 degrees C.
- 2) These are steady state limits. The factory should be consulted on applications involving pulsed or low duty cycle operations.

Thermal Characteristics

TA = 25°C unless otherwise noted

Symbol	Characteristic	Max		Units
		2N5484	*MMBF5484	
P _D	Total Device Dissipation	350	225	mW
	Derate above 25°C	2.8	1.8	mW/°C
R _{θJC}	Thermal Resistance, Junction to Case	125		°C/W
R _{θJA}	Thermal Resistance, Junction to Ambient	357	556	°C/W

*Device mounted on FR-4 PCB 1.6" X 1.6" X 0.06."

2N5484 / 2N5485 / 2N5486 / MMBF5484 / MMBF5485 / MMBF5486

N-Channel RF Amplifier

(continued)

Electrical Characteristics

TA = 25°C unless otherwise noted

Symbol	Parameter	Test Conditions	Min	Typ	Max	Units
OFF CHARACTERISTICS						
$V_{(BR)GSS}$	Gate-Source Breakdown Voltage	$I_G = -1.0 \mu A, V_{DS} = 0$	-25			V
I_{GSS}	Gate Reverse Current	$V_{GS} = -20 V, V_{DS} = 0$ $V_{GS} = -20 V, V_{DS} = 0, T_A = 100^\circ C$			-1.0 -0.2	nA μA
$V_{GS(off)}$	Gate-Source Cutoff Voltage	$V_{DS} = 15 V, I_D = 10 nA$	-0.3 -0.5 -2.0		-3.0 -4.0 -6.0	V V V
ON CHARACTERISTICS						
I_{DSS}	Zero-Gate Voltage Drain Current*	$V_{DS} = 15 V, V_{GS} = 0$	1.0 4.0 8.0		5.0 10 20	mA mA mA
SMALL SIGNAL CHARACTERISTICS						
g_{fs}	Forward Transfer Conductance	$V_{DS} = 15 V, V_{GS} = 0, f = 1.0 kHz$	3000 3500 4000		6000 7000 8000	$\mu mhos$ $\mu mhos$ $\mu mhos$
$Re(y_{is})$	Input Conductance	$V_{DS} = 15 V, V_{GS} = 0, f = 100 MHz$ $V_{DS} = 15 V, V_{GS} = 0, f = 400 MHz$			100 1000	$\mu mhos$ $\mu mhos$
g_{os}	Output Conductance	$V_{DS} = 15 V, V_{GS} = 0, f = 1.0 kHz$			50 60 75	$\mu mhos$ $\mu mhos$ $\mu mhos$
$Re(y_{os})$	Output Conductance	$V_{DS} = 15 V, V_{GS} = 0, f = 100 MHz$ $V_{DS} = 15 V, V_{GS} = 0, f = 400 MHz$			75 100	$\mu mhos$ $\mu mhos$
$Re(y_{fs})$	Forward Transconductance	$V_{DS} = 15 V, V_{GS} = 0, f = 100 MHz$ $V_{DS} = 15 V, V_{GS} = 0, f = 400 MHz$	2500 3000 3500			$\mu mhos$ $\mu mhos$ $\mu mhos$
C_{iss}	Input Capacitance	$V_{DS} = 15 V, V_{GS} = 0, f = 1.0 MHz$			5.0	pF
C_{rss}	Reverse Transfer Capacitance	$V_{DS} = 15 V, V_{GS} = 0, f = 1.0 MHz$			1.0	pF
C_{oss}	Output Capacitance	$V_{DS} = 15 V, V_{GS} = 0, f = 1.0 MHz$			2.0	pF
NF	Noise Figure	$V_{DS} = 15 V, R_G = 1.0 k\Omega, f = 100 MHz$ $V_{DS} = 15 V, R_G = 1.0 k\Omega, f = 400 MHz$ $V_{DS} = 15 V, R_G = 1.0 k\Omega, f = 100 MHz$ $V_{DS} = 15 V, R_G = 1.0 k\Omega, f = 400 MHz$		4.0	3.0 2.0 4.0	dB dB dB dB

*Pulse Test: Pulse Width \leq 300 ms, Duty Cycle \leq 2%

2N5484 / 2N5485 / 2N5486 / MMBF5484 / MMBF5485 / MMBF5486

N-Channel RF Amplifier

(continued)

2N5484 / 2N5485 / 2N5486 / MMBF5484 / MMBF5485 / MMBF5486

Typical Characteristics

Transfer Characteristics

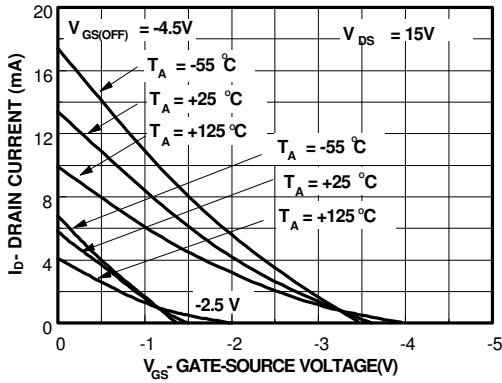

Channel Resistance vs Temperature

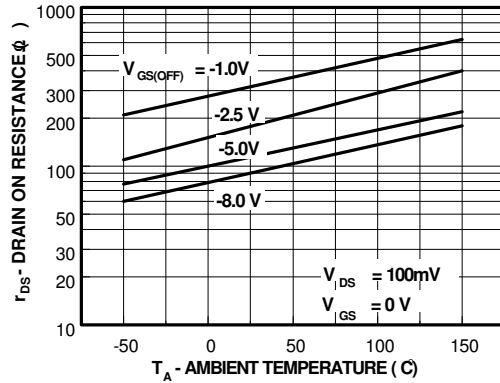

Transconductance Characteristics

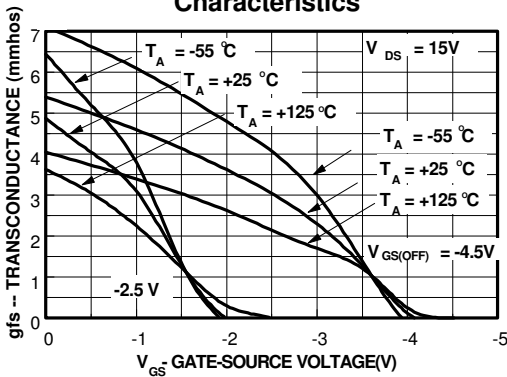

Common Drain-Source Characteristics

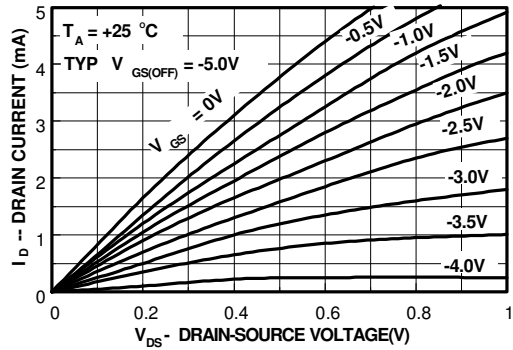

Output Conductance vs Drain Current

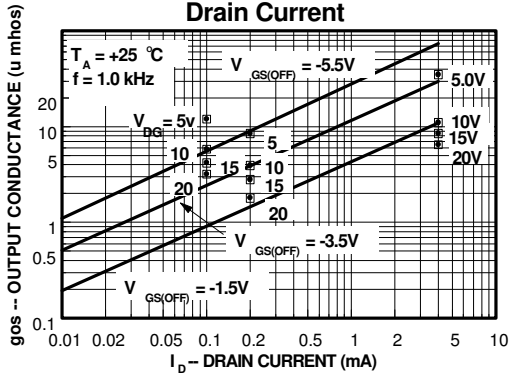

Transconductance Parameter Interactions

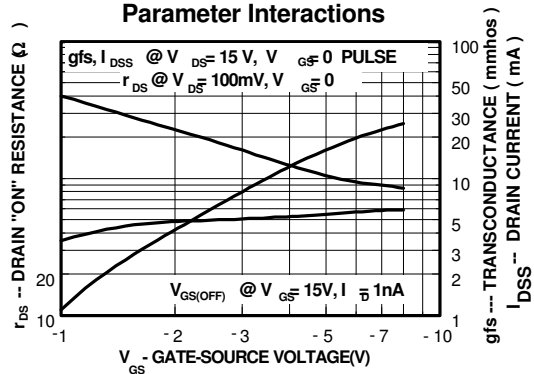

Typical Characteristics (continued)

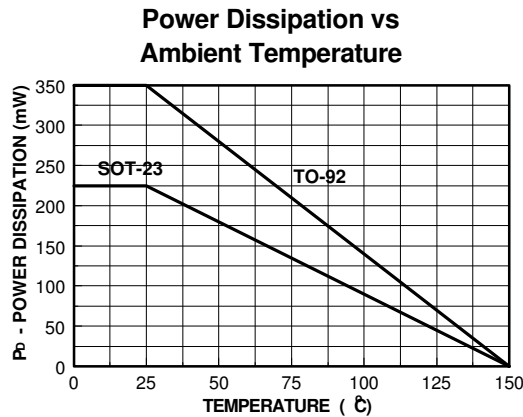
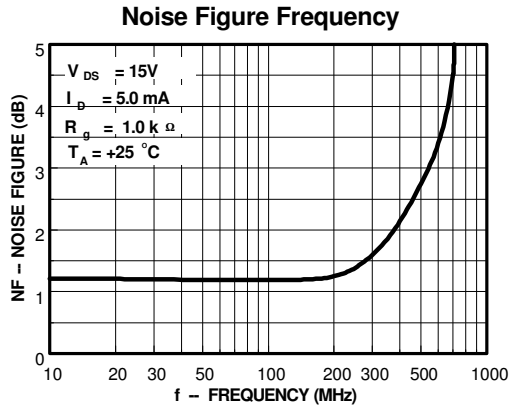
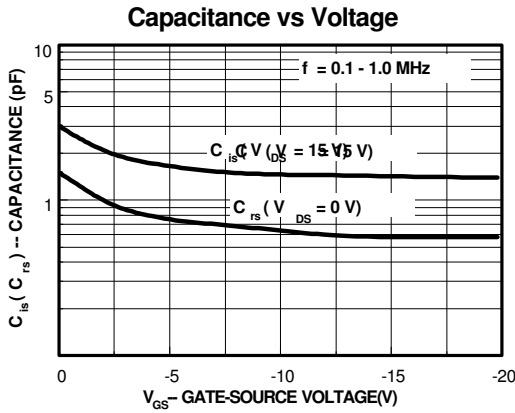
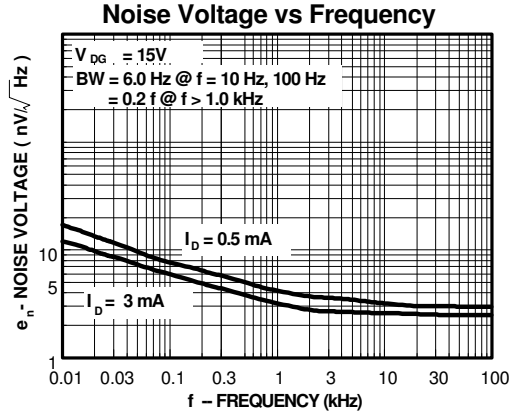
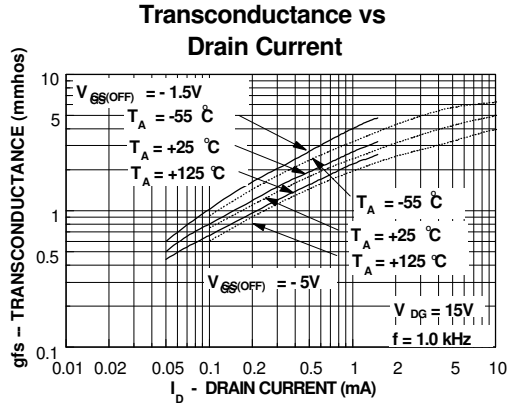

N-Channel RF Amplifier

(continued)

Common Source Characteristics

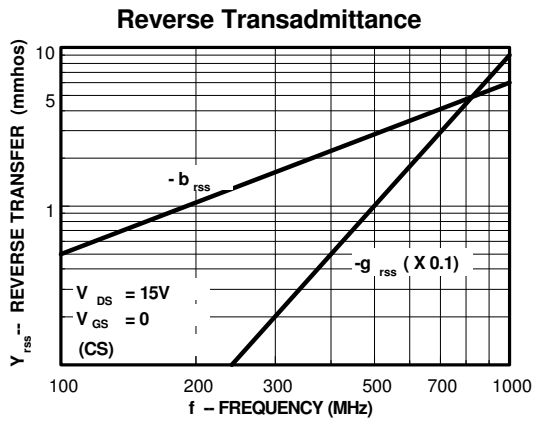
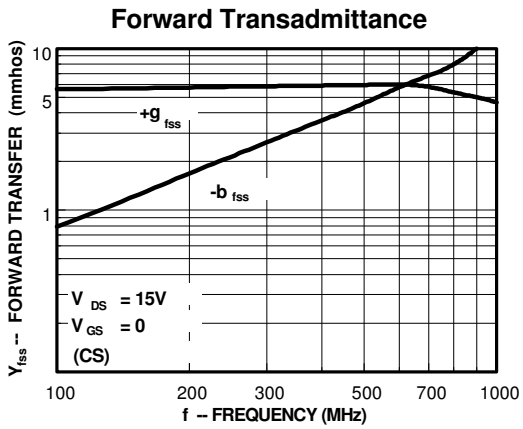
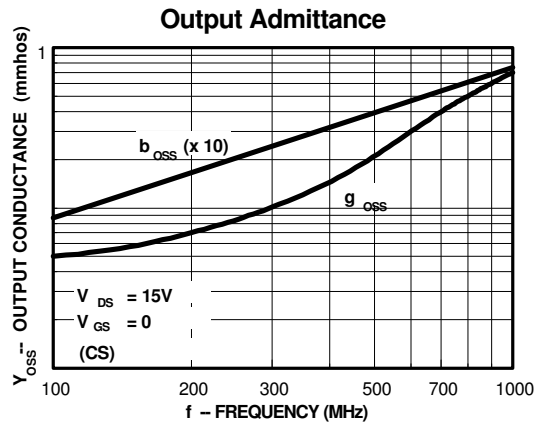
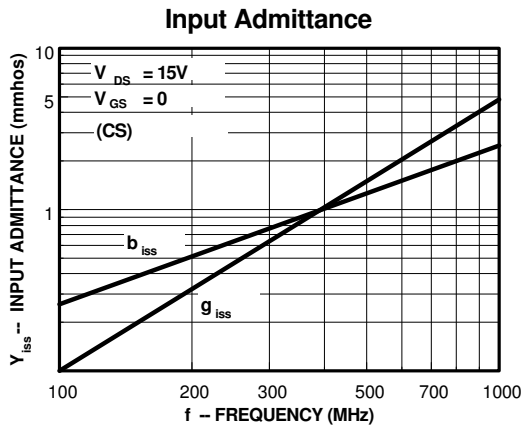

2N5484 / 2N5485 / 2N5486 / MMBF5484 / MMBF5485 / MMBF5486

N-Channel RF Amplifier

(continued)

Common Gate Characteristics

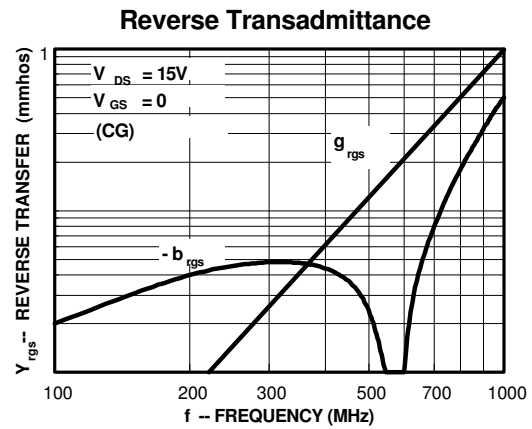
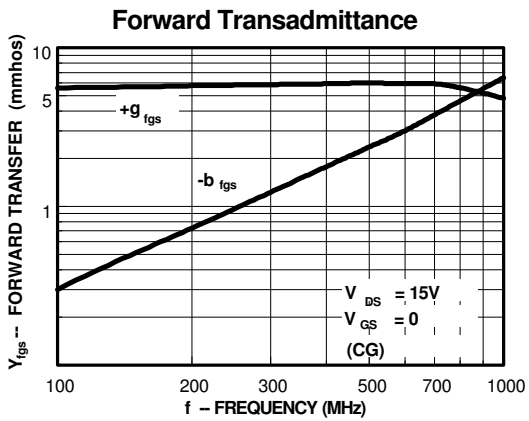
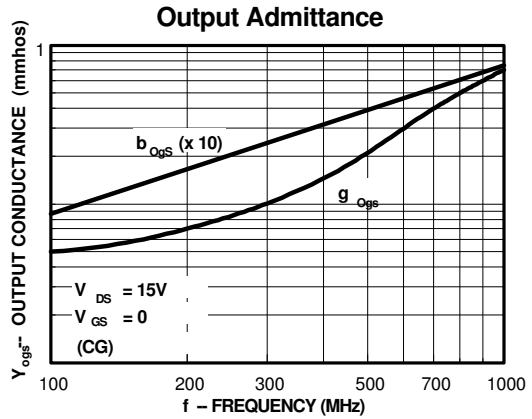
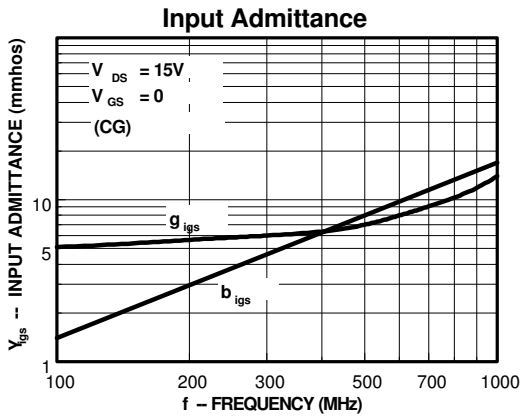

2N5484 / 2N5485 / 2N5486 / MMBF5484 / MMBF5485 / MMBF5486

This datasheet has been download from:

www.datasheetcatalog.com

Datasheets for electronics components.

National Semiconductor was acquired by Texas Instruments.

http://www.ti.com/corp/docs/investor_relations/pr_09_23_2011_national_semiconductor.html

This file is the datasheet for the following electronic components:

2N5486 - <http://www.ti.com/product/2n5486?HQS=TI-null-null-dscatalog-df-pf-null-ww>

2N5485 - <http://www.ti.com/product/2n5485?HQS=TI-null-null-dscatalog-df-pf-null-ww>

2N5484 - <http://www.ti.com/product/2n5484?HQS=TI-null-null-dscatalog-df-pf-null-ww>

MMBF5486 - <http://www.ti.com/product/mmbf5486?HQS=TI-null-null-dscatalog-df-pf-null-ww>

MMBF5485 - <http://www.ti.com/product/mmbf5485?HQS=TI-null-null-dscatalog-df-pf-null-ww>

MMBF5484 - <http://www.ti.com/product/mmbf5484?HQS=TI-null-null-dscatalog-df-pf-null-ww>