

SWITCHING REGULATOR APPLICATIONS

**Features**

- High Voltage:  $V_{DSS}=800V$ (Min.)
- Low  $C_{RSS}$  :  $C_{RSS}=15pF$ (Typ.)
- Low gate charge :  $Qg=62nC$ (Typ.)
- Low  $R_{DS(on)}$  :  $R_{DS(on)}=1.1\Omega$ (Max.)

**PIN Connection**

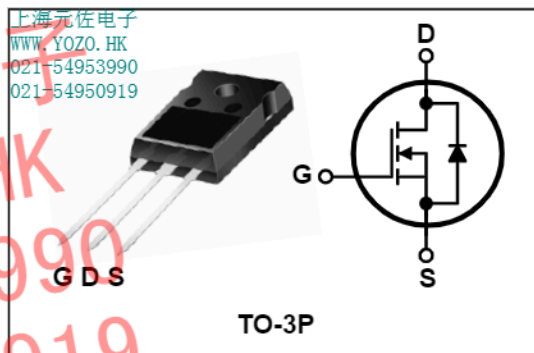

**Ordering Information**

Type No.	Marking	Package Code
SMK1080CI	SMK1080	TO-3P

**Absolute maximum ratings** ( $T_C=25^\circ C$  unless otherwise noted)

Characteristic	Symbol	Rating	Unit
Drain-source voltage	$V_{DSS}$	800	V
Gate-source voltage	$V_{GSS}$	$\pm 30$	V
Drain current (DC)*	$I_D$	( $T_C=25^\circ C$ )	10
		( $T_C=100^\circ C$ )	6.32
Drain current (Pulsed)*	$I_{DM}$	40	A
Drain power dissipation	$P_D$	130	W
Avalanche current (Single) ②	$I_{AS}$	10	A
Single pulsed avalanche energy ②	$E_{AS}$	922	mJ
Avalanche current (Repetitive) ①	$I_{AR}$	10	A
Repetitive avalanche energy ①	$E_{AR}$	24	mJ
Junction temperature	$T_J$	150	$^\circ C$
Storage temperature range	$T_{stg}$	-55~150	

\* Limited by maximum junction temperature

Characteristic	Symbol	Typ.	Max	Unit
Thermal resistance	Junction-case	-	0.96	$^\circ C/W$
	Junction-ambient	-	40	

# Preliminary

上海元佐电子  
 WWW.YOZO.HK  
 021-54953990  
 021-54950919

## SMK1080CI

上海元佐电子  
 WWW.YOZO.HK  
 021-54953990  
 021-54950919

### Outline Dimension

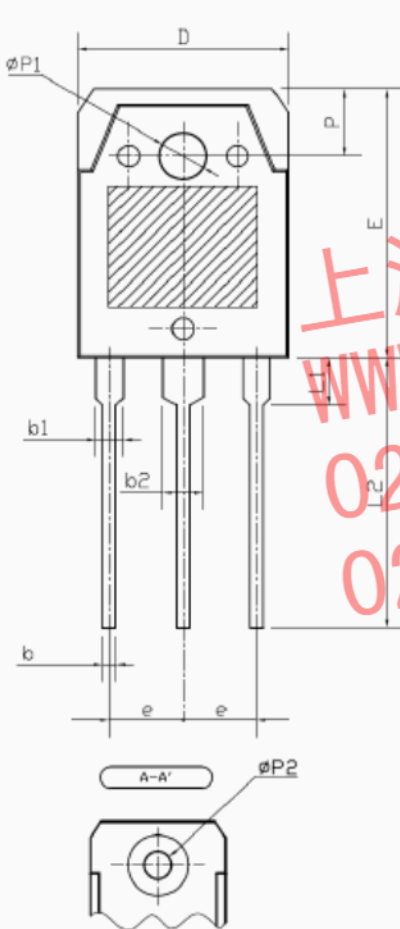

SYMBOL	MIN	NOM	MAX
A	4.60	4.80	5.00
b	0.80	1.00	1.20
b1	1.80	2.00	2.20
b2	2.80	3.00	3.20
C	0.55	0.60	0.75
C1	1.45	1.50	1.65
D	15.40	15.60	15.80
E	19.70	19.90	20.10
e	5.15	5.45	5.75
L1	3.30	3.50	3.70
L2	19.80	20.00	20.20
P	4.80	5.00	5.20
$\phi P1$	3.30	3.40	3.50
$\phi P2$	(3.20)		
Q	1.20	1.40	1.60

**NOTE**

1. THESE DIMENSION DO NOT INCLUDE MOLD/TRIM PROTRUSION
2. < > IS REFERENCE